

MOVE

The magazine for show technology **02|2022**

It's getting hyggelig

Scandinavian coziness as a decoration trend

Black light

Everything about UV light

Colleagues desperately sought

Shortage of skilled workers in the industry

RAFFLE

Win a EUROLITE freeDMX AP Wi-Fi Interface and the full version of the new lighting control app Light Captain!

Galactic sound:

New active speaker from OMNITRONIC

5

Tips for voice recordings in the home studio

Tradition and trends

Christmas traditions through the ages





Dear readers,

what a summer! Festivals, open airs, wedding celebrations - after a two-year break, our calendar of events was packed again this summer. Finally, big events with thousands of visitors were possible again. One of them - the "Greater" festival in Cologne - is presented in this issue.

But as soon as large events were possible again, the shortage of skilled workers in our industry also became clear this summer. Many event service providers are lacking employees. In this issue, we take a look at some of the reasons for this.

In the meantime, the days are getting cooler again and the nights longer; autumn is here. What could be better than curling up in a cozy room and listening to the rain? Exactly this feeling full of coziness is called "hygge" and brings with it a whole furnishing trend, to which we also devote our attention in this issue. Because not only homes, but also hotels, vacation homes, and even event spaces can benefit from a little more "hygge"!

What else awaits you in this MOVE: Things worth knowing about artificial fog, product innovations from the lighting and audio sectors, interesting facts about attachment gear and much more. In preparation for the cold season, we will also take a look at Christmas traditions through the ages.

As always, we hope you enjoy reading and wish you a happy winter season!

Your MOVE editorial team

EDITORIAL

CONTENTS



REPORTS

- 18** **Musical stars in the best light**
Charity musical gala in Heidenheim
- 23** **Shining personalities**
“Greater Festival” in the Cologne Lanxess Arena
- 26** **Shopping in a new light**
Salesrooms of “The Sting” in The Hague
- 30** **Lightshow for electro beats**
Castle-X-Party in Seefeld/Tyrol
- 46** **Wine presentation of a special kind**
Spremberg Castle shines
- 74** **Strong sound for strong performances**
Baseball stadium in Regensburg
- 76** **A visual and acoustical highlight**
Café Zentral in Amberg

TIPS AND SERVICE

- 20** **Lots of colorful smarties**
Smart light in private and hotel rooms
- 34** **Securely fastened**
Attachment gear in event technology
- 38** **Black Light?**
UV light and its use
- 41** **Who, what and when?**
Protection of minors at events
- 58** **Ask Doc Fog**
Questions and answers about fog fluid
- 60** **Repair and reduce**
Reduce electrical waste with spare parts
- 68** **Home-made with love**
Tips for good voice recordings
- 71** **Good sound in every corner**
Installation solutions for the sound system

TRENDS

- 48** **Living trend Hygge**
Scandinavian coziness for autumn
- 54** **How to spookify**
Design ideas for the Halloween party
- 78** **About trends and traditions**
Christmas traditions through the ages
- 82** **Relaxing lounge**
Cozy terrace in Viernheim

INTERVIEW

- 32** **Colleagues desperately sought**
Interview with Jochen Habermann on the subject of shortage of skilled workers



PRODUCTS

- 04** **Easy to transport**
Mobile foldable DJ table by OMNITRONIC
- 06** **Lots of effect in a small space**
LED Compact Multi FX Laser Bar by EUROLITE
- 08** **Fits perfectly in any corner**
AKKU PT-100/32 Pixel DMX Tube by EUROLITE
- 10** **White light in compact format**
New spotlights from EUROLITE
- 11** **Recharge batteries in case**
ROADINGER Flightcase 4x AKKU BAR-6
- 12** **What does the new app offer?**
FAQ about the app Light Captain from EUROLITE
- 24** **Set visual accents**
Neon Flex by EUROLITE: Neon light, but flexible!
- 28** **Leave them out in the rain!**
FUTURELIGHT IP PLB-420 and IP PLH-420
- 36** **Updates**
EUROLITE launches V2 and V3 for Easy Show Controller
- 66** **Galactic performance**
XIRA from OMNITRONIC
- 84** **Safety first!**
DIMAVERY ABS Cases



P.86

*Solve the "letter salad" challenge.
Enter now and win a premium version of
the new EUROLITE Light Captain App!*

NEWS



MOBILE, FOLDABLE DJ TABLE FROM OMNITRONIC

Easy to transport, quickly set up and visually appealing - that's the new Mobile DJ Stand from OMNITRONIC. Thanks to its folding mechanism, it can be set up in just a few steps and then provides stable support for everything the mobile DJ needs to work: controllers and players find their place on the tabletop and are discreetly hidden by the matching fabric cover from the front.

In addition, the Mobile DJ Stand can be extended with two corner plates to another level, on which, for example, small lighting effects find their place. The foldable frame made of steel and aluminum weighs only 10.5 kg and can be transported in the included bag to save space.

Made of a lightweight and foldable aluminium frame, the DJ stand offers you a work surface of 105 x 52 cm. The working height is 95 cm.



Packing size under 120 cm length

ONLY 10.5 kg

OMNITRONIC Compact Mobile DJ Stand incl. Cover

Portable DJ table with panelling for mobile applications



Optional accessories: corner plates incl. bag
Perfect for placing boxes, lights or laptops



Carry bag included



White cover included, black cover optionally available



Assembly without tools



Compact, foldable design

NEWS



- REMOTE CONTROL
- DMX
- MASTER SLAVE
- STAND ALONE
- LASER 2M
- Speaker icon
- CW
- Color selection icons (red, green, blue, grey, orange)
- RGBWA
- QuickDMX USB
- STROBE

EUROLITE LED Compact Multi FX Laser Bar

MATRIX, BLACK LIGHT, LASER AND STROBE

LOTS OF EFFECT ON LITTLE SPACE

The LED Compact Multi FX Laser Bar by EUROLITE brings four effects - and that in the smallest nook: With a space requirement of only 40 cm, the little bar finds a suitable corner for itself in every party room and then provides a surprisingly powerful light show. It combines a matrix effect in RGBWA with UV light, a class 2M laser and SMD

LEDs for a stroboscopic effect. In addition to the built-in automatic programs, the compact light effect offers the possibility of control via the included remote control as well as via DMX (also wirelessly via QuickDMX via USB). The compact bar can also be controlled via the Light Captain app (additional FreeDMX interface required).

EUROLITE AKKU PT-100/32 PIXEL DMX TUBE

UP TO 9 HOURS
BATTERY OPERATION



12 INTEGRATED SHOWPROGRAMS

CONTROL VIA DMX

SUBDIVIDED INTO 32 PIXELS

DIRECT COLOR SELECTION FOR
17 PRESET COLORS

INCL. 2 BRACKETS AND STAND

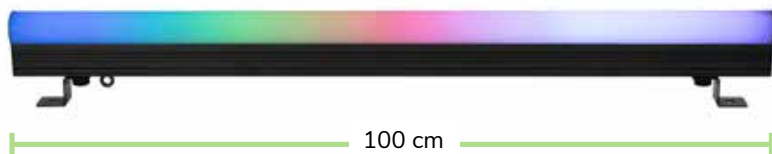

100 cm

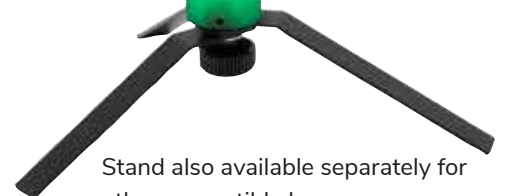

Stand also available separately for
other compatible bars.

The **EUROLITE Akku PT 100/32** is a flexible design element for mobile applications, which can even be used for pixel effects.

The 100 cm high bar can be mounted with the help of two brackets, but also comes with a stand. With this, it can stand freely and thus be used, for example, in the corners of a room, as a design element on a show stage or in a larger crowd as an impressive matrix. Inside the unit, 96 powerful SMD 5050 LEDs are installed, which are based on RGB color mixing. Every three LEDs make up one pixel, so that up to 32 individually controllable pixels are available.



Wireless QuickDMX receiver



The battery used allows an operating time of about nine hours. The control is done via DMX. In the smallest mode with three channels, the mixture of the three colors can be adjusted. In the largest mode with 96 channels, each pixel can be controlled individually. In between, there are various DMX modes with different possibilities. For the DMX signal, the tube is equipped with a USB socket into which a wireless DMX receiver can be connected. This is available for EUROLITE's own QuickDMX system as well as for Wireless Solution and Lumen Radio systems. But of course the bar can also be operated in stand-alone mode.



LED PFR-50 WW

With the PFR-50, EUROLITE offers a new spotlight with a fresnel lens. Its light comes from a 20 watt warm white LED with high color rendering index. A power of 20 watts sounds little at first, but the LED is extremely effective and thus puts even much more powerful models in the shade in terms of light output. The beam angle can be adjusted from 11° to 40° via a manual zoom. With the help of the optionally available barndoors, the light can be shaded. The PFR-50 is ideally suited as a spotlight for exhibitions and trade fairs. The DMX module can be used optionally; if the spot is operated without it, it can simply be switched on via the mains. With DMX module it can be operated via any DMX lighting console.



EUROLITE LED PFR-50 WW Fresnel Spot

Compact spotlight with 20 W COB LED, manual zoom, color rendering index (CRI) >95



EUROLITE LED PPC-20 WW Spot

Fanless spotlight with 20 W COB LED, adjustable beam angle, color rendering index (CRI) >95



LED PPC-20 WW

The PPC-20 is a particularly small and cost-effective spotlight that nevertheless produces excellent white light. A PC lens sits in the tube, which can be set to different positions thus determines the beam angle. Settings of 10°, 15°, 18° and 22° are possible. Inside the small spotlight, an effective 20 W LED is used. The brightness can be manually adjusted via a rotary control on the rear of the device. External control is not provided for this spotlight.

Flexible battery bar

The Akku Bar-6 Glow from EUROLITE can be used flexibly: Upwards, six tiltable LED lenses emit light and therefore make the bar an ideal uplight or spotlight. At the side of the bar, a luminous surface serves as a mood light, for example, for ambient lighting.

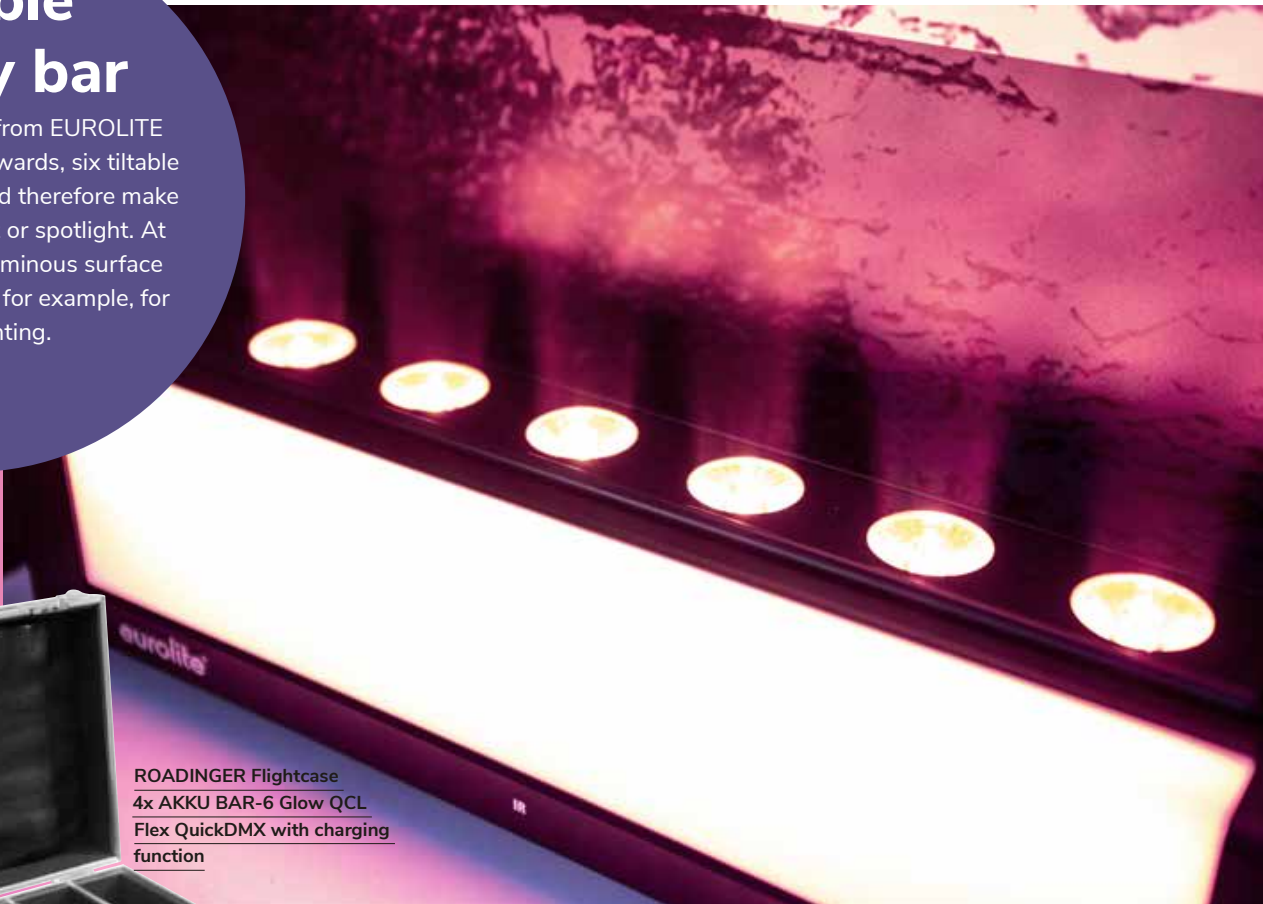

ROADINGER Flightcase
4x AKKU BAR-6 Glow QCL
Flex QuickDMX with charging
function

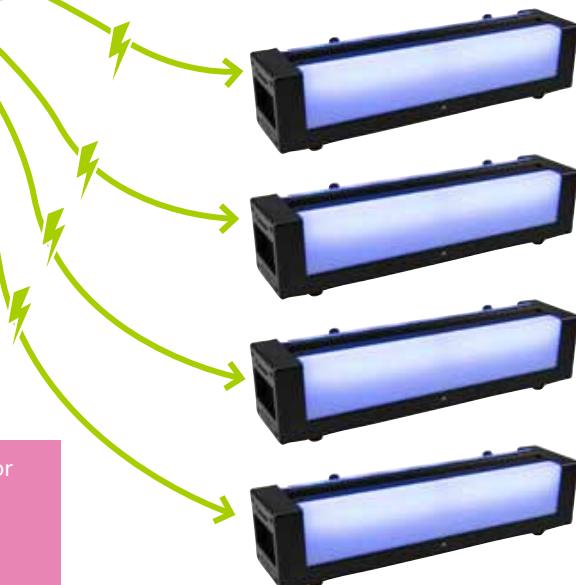

INFO

- + 4 compartments for devices
 - + Extra accessory compartment
 - + P-Con connections
 - + Robust castors
 - + High-quality butterfly locks
- Also available as a set

 QuickDMX[®]
EUROLITE AKKU Bar-6
Glow QCL Flex QuickDMX

Tiltable battery-powered LED bar and mood light with 4in1 LEDs and QuickDMX



Practical charging case

A particularly convenient feature is the accompanying case with a charging function, which can accommodate four devices at the same time. The case is connected to the power supply via P-Con connectors, and the battery bars can then simply be placed in the case for charging. In addition to the devices, cables and other accessories can also be stored in an extra accessory compartment.

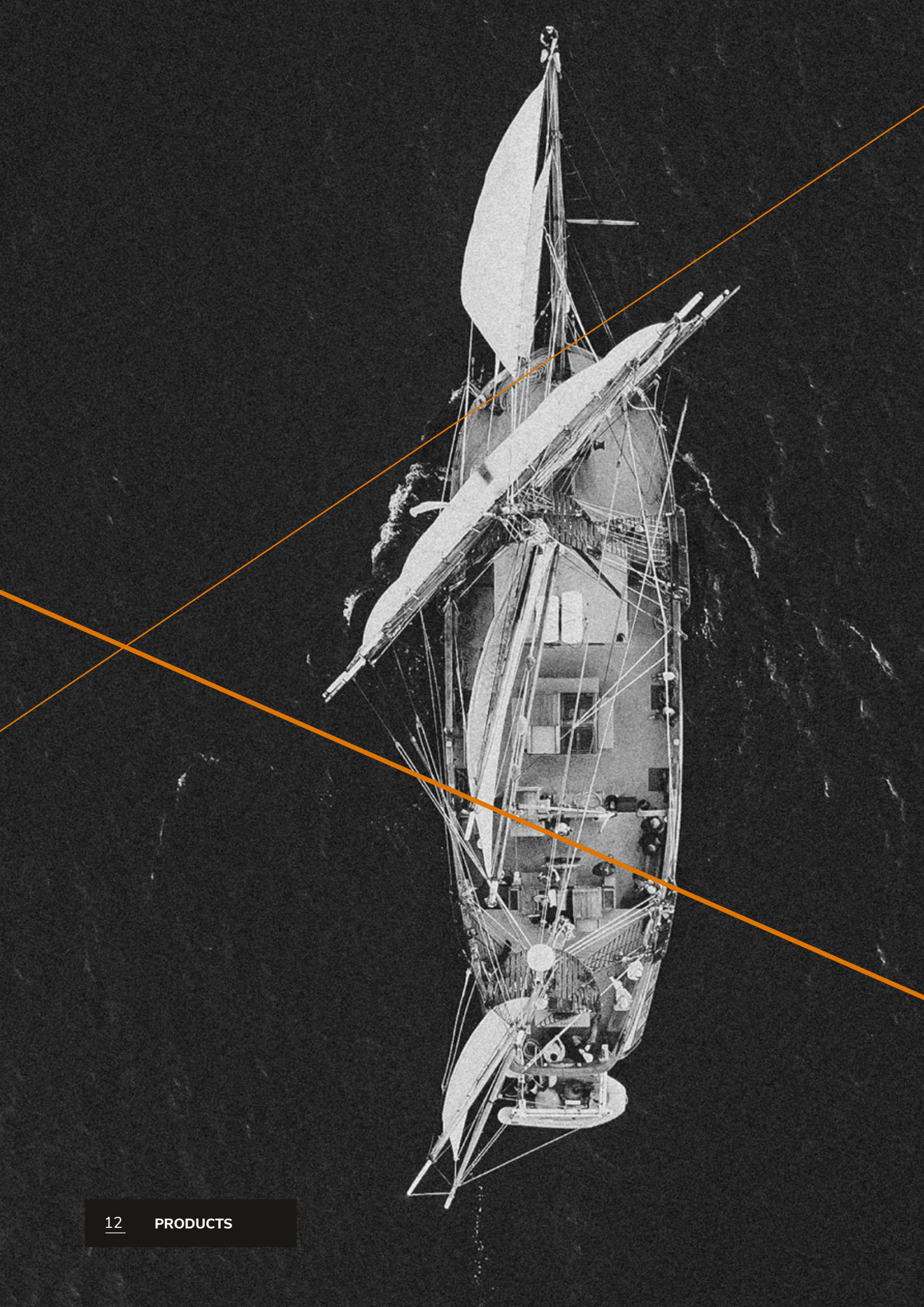



FAQ

Light Captain

In our previous issue, we already introduced you to EUROLITE's new lighting control system, Light Captain. Today we give you answers to the most frequently asked questions about the app.



Coming
soon



FAQ Light Captain

What is Light Captain?

Light Captain is an app that allows you to control DMX fixtures in a simple way. Despite the almost intuitive operation, Light Captain enables professional results.

What can I control with Light Captain?

The app is designed to clearly display many different functions. Even complex fixtures with many functions and DMX lasers can be controlled with Light Captain. Up to 4 segments can be controlled in color mixing, so even KLS systems (i.e. a bar with four spotlights) or spotlights with 4 segments can be controlled.

For what kind of events is the Light Captain recommended?

There are two fundamentally different interfaces to program the lights and control the show. The first interface is ideal to control the light spontaneously with different moods and scenes. Parties or concerts without a fixed schedule can be managed here in a simple, clear, and versatile way. In the second area, it is possible to provide lighting for performances or concerts with a fixed schedule. Theaters, musical productions or concert shows, in particular, will feel right at home here. In this mode, two shows as well as three lighting scenes (e.g. for hall light, front light, haze...) can be combined as desired.

On which devices does Light Captain run?

The software is currently available for IOS (Apple) and Android tablets. On IOS the app works from version 14.5, on Android the size of the screen and the resolution are important, in addition to the processing power. Reasonably up-to-date devices with at least 10 inches are recommended.

Does Light Captain also work on cell phones?

No. Unfortunately, this is not possible, because the screen size is simply too small.

How do I get the signal from the tablet?

This works with the EUROLITE Free DMX Interface. A WLAN connection is established between this and the tablet, the interface then outputs the DMX commands. A WLAN network is not needed for this, the interface and tablet create a small network themselves that does not need any secondary technology.

Is there also a wired option?

The current version of the EUROLITE Node 1 Interface can be used as a wired interface for operating the Light Captain. You still need a standard RJ45 adapter for the tablet - ideally with a power adapter so that the tablet can generate and charge the DMX signal at the same time.



Light Captain Facts

- Simplest operation for complex and professional lighting programming
- Each fixture can be color controlled in 4 segments
- Color mixes with up to 8 basic colors clearly displayed
- Separate effect section for color effects with 6 pre-programmed effects that can also be modified
- 16-bit capable control for the movement of moving lights
- Effects unit that can be used to create motion effects quickly and effectively.
- Gobos, prisms, zoom and focus can be clearly adjusted on the control level.
- 8 freely assignable Freepatch controls
- "Precues" for frequently used settings (15 general memories, 15 color memories and 15 move memories)

Is there a device library?

Yes, there is already a large library of pre-programmed devices that is constantly growing.

Can I create my fixtures that are not from EUROLITE?

Yes! During the development of Light Captain, we made sure that the creation of devices is as easy as possible and without any restrictions. Even complex devices with many functions can be patched and controlled in a very short time.

Can the app control movements in 16-bit?

Yes, this is provided for. Both 16-bit and 8-bit movements can be controlled without any problems.

Are there motion and color effects?

Both can be found in Light Captain. For the color effects, you can even easily generate your own color sequences and use them as effects. The motion effects can be created for both axes separately in their deflections, speeds and delays.

How many spotlight colors does Light Captain support?

Light Captain can control spotlights with up to 8 different base colors and one color wheel.

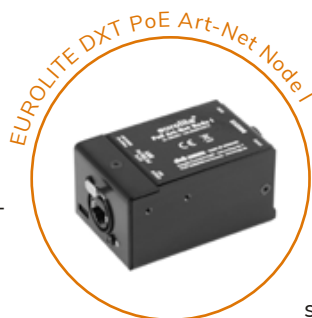

For which users is Light Captain recommended?

Since Light Captain is very versatile, many users will feel at home here: Whether a mobile DJ, solo entertainer, band, concert promoter, theater or musical. The app is also very interesting for rental companies, as it also offers a password-protected area where lighting scenes can be set, but nothing can be changed or deleted.

Is it possible to manage different shows?

It is possible to create different setups and shows and also save them.

Is it possible to exchange shows or individual devices with other users/tablets?

You can send whole shows as well as single fixtures by mail to other tablets and use them there.

How much does Light Captain cost?

The trial version with limited options can be downloaded from the app stores for free. For 19.99 Euro you get the basic version, which already offers many options. For 39.99 Euro you get the full version with all features. The amount is only due once and includes a license without a time limit.

Light Captain Top Features



Theater

The theater mode allows crossfades with fade in and fade out time. Two scenes can run simultaneously and their brightness can be adjusted individually. Three moods allow simultaneous recall of independent functions such as room lighting, fog, or any other lighting tasks.



Chases

Chases and flash cues allow a fast and effective light control, of course also sound controlled. Chases can be set to run simultaneously, consecutively, or individually.



Move

In the Move section, spotlights can be controlled with 8-bit or 16-bit movement resolution and movement effects can also be created quickly and efficiently.



Precues

Precues make programming much easier, as you can store frequently used color settings, movement positions, or general moods here so that you can use them again and again in programming.

Antari[®]
FOG MACHINE

*Strolling ...
with boundless snowflakes around*

SNOW MACHINE
S-600 

- > 2 in 1 powerful fan and blower to bring snowflakes up to 20 meters!
- > Adjustable snowflake size from fine snow to blizzards
- > Wireless remote control
- > Built-in electronic controls and timer
- > DMX / RDM on board



FOLLOW ANTARI



Antari 



**FUTURELIGHT EYE-37 RGBW
Zoom LED Moving Head Wash**

PRO washlight with RGBW color mixing, very large zoom range and Art-Net



**BENEFIZ MUSICAL GALA
// KONZERTHAUS HEIDENHEIM**

In June 2022, after a two-year break, the "Benefiz Musical Gala" of musical sehnsucht e.V. took place again in the Konzerthaus Heidenheim. Andreas Zöllner was responsible for the lighting design of this event. Among other things, moving heads from FUTURELIGHT as well as light strips and theater spots from EUROLITE were used.



EUROLITE LED PMB-8 COB QCL 30W Bar
LED light effect bar with RGBW color mixing





In order to skilfully stage the actors of well-known musicals, the following of our products were used:

- 7x FUTURELIGHT DMH 300 Moving Head
- 8x FUTURELIGHT Eye 37 Moving Head
- 4x FUTURELIGHT Eye 740 Moving Head
- 11x EUROLITE PMB 8 QCL Bar
- 3x EUROLITE Par 64 COB RGBW Spot
- 2x EUROLITE SL 400 Follow Spot



FUTURELIGHT DMH-300 CMY Moving Head

PRO beam/wash moving-head with 270 W COB LED, large zoom and CMY color mixing

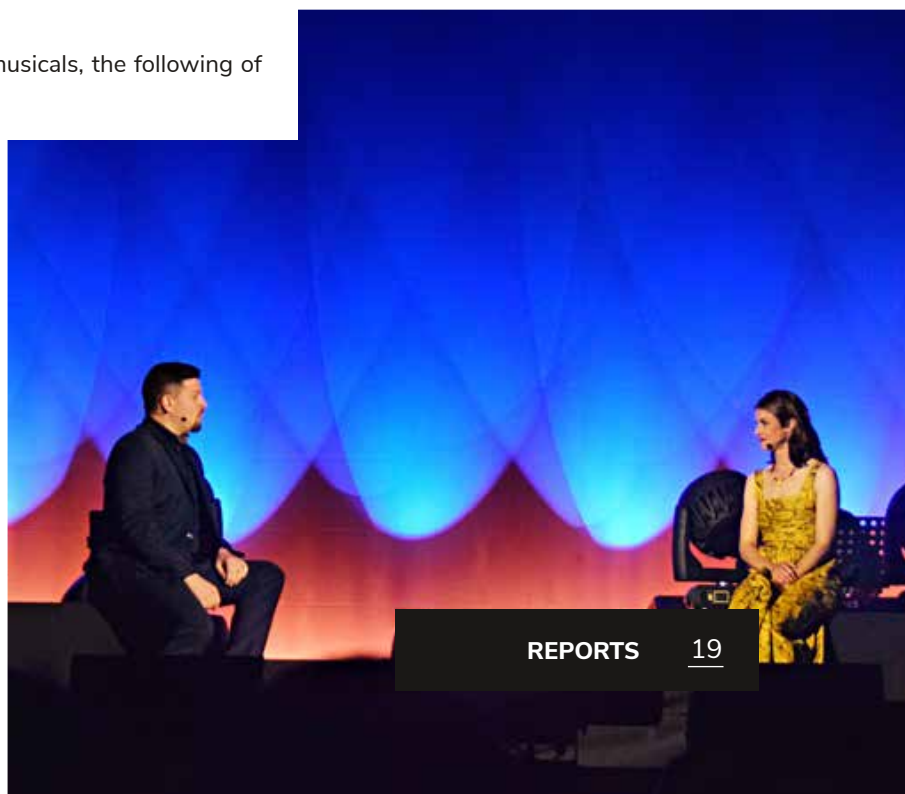



LET THERE BE SMART LIGHT!

Smart light in the
private and hotel sector



Following the triumph of LEDs in professional lighting technology, colorful and centrally controllable light has also found its way into the private sector in recent years: Many living rooms now feature LED strips for indirect lighting, lamps respond to voice commands and transform living rooms into home theaters within moments or bathrooms in an evening lighting mood. So-called "smart" devices, which are connected to each other and to the control system via the Internet, make this possible. For private rooms as well as for hotels and vacation homes, the systems offer clear advantages beyond pure convenience - we present some of them.

Modern look in no time at all

Your existing rooms are still perfectly fine, but could use a visual update? Smart LED strips are perfect for providing modern, indirect lighting. The strips can be mounted on the back of TV cabinets or on finishing strips on the wall, for example, in just a few minutes. They can then be conveniently controlled by remote control; alternatively, they can be integrated into an existing WLAN network so that they can also be controlled via app and connected to other smart home devices.



SMART TIP

The joint control of smart devices also works even when different apps are used, e.g. when Amazon Alexa/Google Assistant or similar are used as additional (voice control) apps. Here, it is then a matter of integrating all smart devices from the various apps and grouping them as desired. For example, a room equipped with an LED light fixture from the Smart Life app and an LED strip from the Tuya app can be controlled via the Alexa app/Google Assistant.



From 0 to party in three seconds

Particularly practical in hotels and event venues: thanks to RGB/WW/CW LEDs, the smart lighting elements can be used not only to create warm or cool white basic moods, but also to use multi-color programs and scenes suitable for parties. Various color change modes enable the right selection for the music style. Any commercially available E27/PAR-30/GU-10 socket fits as a light source connection here. Event rooms, bars or restaurants are thus color-matched to the respective events without additional color spotlights.



CRI > 80

OMNILUX LED E27/PAR-30
RGB/WW/CW WiFi

Smart WLAN lamp RGB+CCT, controlled via App, Alexa & Google Home



E27



PAR-30

Accessibility rethought

Smart lighting systems are not only particularly convenient - they can also make a significant contribution to accessibility. On the one hand, voice control accommodates people with limited mobility; on the other, additional automations can ensure, for example, that the light always comes on as soon as a door is opened.

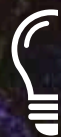

SMART TIP

By additionally integrating smart door/window contacts, motion detectors, light sensors or NFC tags*, many other automations can be created with a suitable app on tablets and smartphones. For example, when a door or gate is opened, the lighting for paths, gardens, rooms or halls can be switched on automatically. Simultaneous playback of media files such as announcements (accessibility), information (museums), directions or music/video can also be programmed on iOS and Android.

SMART TIP

Light sources can be created individually or as a group in the app and then controlled by voice or via the smartphone/tablet. Schedules can also be used to automate different moods, colors and brightnesses, for example to automatically light stairs at night and switch them off again in daylight.

Staircase lighting with smart GU10 bulbs.

Especially in existing buildings, retrofitting recessed or surface-mounted luminaires with the appropriate wiring is not always possible. Existing systems can still be retrofitted inexpensively, quickly and easily by using smart replacement lamps.



OMNILUX LED GU10 RGB/WW/CW WiFi
Smart WLAN lamp RGB+CCT, controlled via App, Alexa & Google Home



PRODUCT TIP

This EUROLITE 5in1 controller can manage RGB/WW/CW strips as well as pure RGB, warm white or cool white strips. It is controlled via app or an optionally available remote control. An additional 12V/24V LED power supply is required for operation.



EUROLITE LED Strip 5in1 WiFi Controller

Smart 5-channel WiFi controller for RGB/W+CCT LEDs with app, Alexa & Google control



Connection examples 5in1 controller



EUROLITE LED Strip Remote Controls for 5in1 Controller

Remote controls for 5 colors (RGB/W and dual white). Black variant with additional zone function



EUROLITE LED Strip 300 5m 5050 RGB/WW/CW 24V

Flexible LED Strip, RGB, Warm White and Cool White



EUROLITE LED Strip 600 5m 3528 2700+5700K 24V

Flexible LED strip, warm white and cool white, CRI >90

Single color LEDs

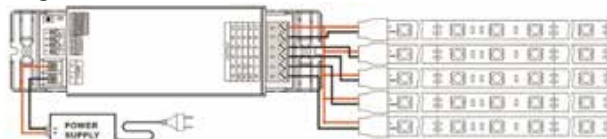

White light LEDs with variable color temperature

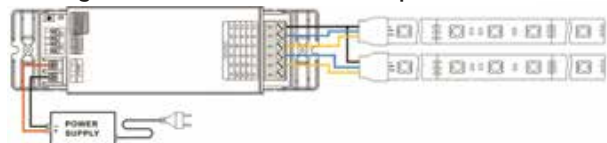

RGBW LEDs

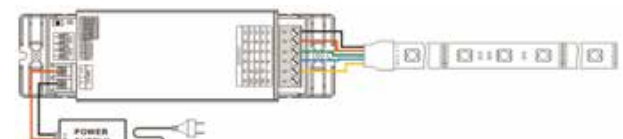

RGBCW LEDs or RGB+CCT LEDs

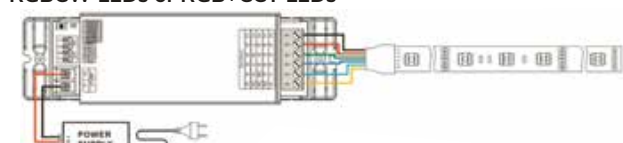



GREATOR FESTIVAL // COLOGNE

On July 29 and 30, 2022, the coaching provider “Greater” invited to its popular festival in the Lanxess Arena in Cologne. More than 100 speakers on three parallel stages and stars like Culcha Candela and Mike Williams could be experienced by the more than 10,000 participants. Technically, the event was completely organized and supervised by the company WIRKUNG from Boxberg.

The team of WIRKUNG.live took care of the technical equipment of the festival, WIRKUNG.media of camera technology and recording and WIRKUNG.digital of streaming and IT. 50 people were in charge of the event, nine trucks transported technology to Cologne and two days were needed to set everything up. In the end, there were 150 m² of LED wall, more than 400 light fixtures and three stages that could be played in parallel. Among other things, more than 300 meters of ALUTRUSS truss, 30 EUROLITE AKKU Bar-6 Glow, 24 EUROLITE Mini AKKU IP UP-4 QCL, 30 EUROLITE AKKU IP UP-4 QCL WDMX and 16 EUROLITE Multiflood Pro IP RGBW were used.



EUROLITE AKKU Bar-6 Glow QCL Flex QuickDMX

Tilttable battery-powered LED bar and mood light with 4in1 LEDs and QuickDMX



EUROLITE AKKU Mini IP UP-4 QCL Spot

Mini battery uplight IP65 with RGBW LEDs and IR remote control



EUROLITE Multiflood Pro IP RGBW Wash MK2

Bright outdoor spot with RGBW LEDs and W-DMX





eurolite® NEON flex

LED Neon Flex

In 1909, the Frenchman Georges Claude invented red luminescent glass tubes filled with the gas neon, to whose electrodes a high voltage was applied, causing the gas to glow. And even if other colors were produced by other gases or luminescent substances, the so-called neon tube kept its name from then on. The glowing tubes, which glassblowers could shape into a wide variety of forms, opened up com-

pletely new possibilities with lettering and colors that are still used today in art and advertising.

An alternative suitable for everyday use is **Neon Flex**: Here, we are not dealing with gas-filled glass tubes and high voltage, but with **LEDs in flexible light tubes**. Visually, there is hardly any difference to “real” neon tubes.

EUROLITE now offers 5-meter-long **Neon Flex sets**, which can be used to easily create your own lettering, graphics, but also room accents.



The finished sets come with power supply, supply cable and mounting clips and are available with 6 different light colors.

EUROLITE LED Neon Flex 24V 5m Set



warm white



green



red



cold white



blue



yellow



RGB color change



RGB multicoloured or uni

**EUROLITE LED Neon Flex 24V RGB
5m with IR Set**

**EUROLITE LED Pixel Neon Flex
12V RGB 5m with IR Set**

In addition, there is also a set with color mixing, where the desired color can be set by yourself via an IR remote control and changed at any time.



All systems are IP-44 certified and therefore also suitable for outdoor use.

THE STING



SALESROOMS OF “THE STING” // THE HAGUE

ST-shop - Licht & Geluid from The Hague (Netherlands) has created real eye-catchers in the sales areas of THE STING with the help of over 50 LED bars from EUROLITE.

The milky plastic housing of the light sticks ensures both a beautiful appearance and atmospheric illumination during the shopping experience.

Integrated programs for color change and color fading, as well as the included IR remote control make operation easy for the fashion store employees.





EUROLITE LED Neon Stick 134cm RGB

LED color tube with floor stand and IR remote control

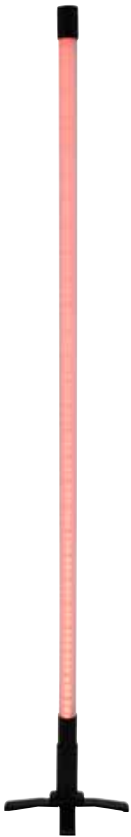

IP STANDARDS

The degree of protection indicates the suitability of electrical equipment (for example, devices, luminaires and installation material) for various environmental conditions, in addition to the protection of people against potential hazards during their use. Protection classes are IP00 to IP6K9K (ISO 20653) or IP69 (DIN EN 60529).

1st Digit	Meaning:	
ISO 20653 DIN EN 60529	Protection from foreign bodies	Protection from contact
0	No Protection	No Protection
1	Protected against solid foreign bodies with diameter ≥ 50 mm	Protected against the access with the back of the hand
2	Protected against solid foreign bodies with diameter ≥ 12.5 mm	Protected against access with a finger
3	Protected against solid foreign bodies with diameter ≥ 2.5 mm	Protected against access with a tool
4	Protected against solid foreign bodies with diameter ≥ 1.0 mm	Protected against access with a wire
5k	Protected against dust in harmful quantity	complete protection against contact
6k	Dustproof	complete protection against contact

2nd Digit	Meaning:
ISO 20653 DIN EN 60529	Protection against water
0	No Protection
1	Protection against dripping water
2	Protection against falling dripping water when the housing is tilted up to 15°.
3	Protection against falling spray water when inclined up to 60°.
4	Protection against splashing water from all sides
4k	Protection against splashing water from all sides with increased pressure
5	Protection against water jets (nozzle) from any angle
6	Protection against strong jets of water
6k	Protection against strong jets of water under increased pressure, specific for road vehicles
7	Protection against temporary immersion
8	Protection against permanent submersion. Unless otherwise specified, protection is provided up to a water depth of 1 meter. Other water depths must be specified or agreed separately.
9	Protection against water during high pressure/steam jet cleaning, especially agriculture
9k	Protection against water during high pressure/steam jet cleaning, specific for road vehicles





FUTURELIGHT IP PLB-420 and IP PLH-420



LEAVE THEM OUT IN THE RAIN!

These two new moving heads from FUTURELIGHT can be left out in the rain: Both carry the protection class IP 65, so they are even protected against water jets. Even in the pouring rain, they can be operated safely. Both are equipped with very bright 420 W discharge lamps that provide the necessary brightness even for large open-air productions. The difference between the two versions:

The PLB-420 is a fixture specialized in beams, while the PLH-420 is a hybrid fixture that combines spot, beam and wash. The hybrid PLH-420 offers high light output combined with a very versatile feature set: its zoom optics create beam angles between 1° and 14° in beam mode and between 4° and 25° in spot mode. In beam mode, it creates a deliberate hotspot for the highest possible light pressure, in spot mode an extremely homogeneous image for uniform projections. The moving head is equipped with 9 rotating, interchangeable gobos as well as 14 fixed gobos and has two rotating prisms. The first prism creates 8 images arranged in a circle, the second creates 6 images in a line. A frost filter softens the light for a washlight effect; this feature is also adjustable in size using the zoom. In addition, there are 14 different colors.

The Beamlight PLB-420, on the other hand, specializes in narrow beams. So the moving head is not as versatile as the hybrid. But if you set both versions to the narrowest beam angle of 1°, you can see that the PLB-420 is ahead in terms of brightness. It, too, features two rotating prisms, which, however, affect the optics in a different position and therefore offer a brighter and more intensive result. In addition to the "normal" 8-fold prism, the spotlight also has an extraordinary honeycomb prism on board, which visually creates an interesting effect. Also with the beamlight, there is the option to soften the light with the help of a frost filter.

So if you're looking for a pure beamlight for impressive effects in fog, you'll be in for a real treat with the PLB-420. If you are also looking for projections and versatility, we recommend the PLH-420.



FUTURELIGHT PLB-130 Moving-Head

PRO beam moving-head with 150 W COB LED and many features



Manfred Zach, EVENTus - Veranstaltungstechnik



PROJECT CASTLE X-PARTY // SEEFELD IN TYROL

On May 14th, 2022 the Project Castle X-Party took place at the Magic Castle Seefeld in Tyrol (Austria). With 12 DJs on 2 floors, the party was packed with House, Charts, Future House, EDM and Hardstyle. The event was organized by Blacklight Events & Urbanground. The technical management of the event was done by EVENTus - Veranstaltungstechnik.



The following devices were used in this production:
 10 x FUTURELIGHT PLB-280 Moving-Head
 12 x FUTURELIGHT DMH-160 MK2 LED Moving-Head
 8 x FUTURELIGHT PLB-130 Moving-Head



FUTURELIGHT PLB-280 Moving-Head Spot/Beam

PRO spot, beam and wash moving-head with 280 W discharge lamp



FUTURELIGHT DMH-160 MK2 LED Moving-Head

PRO moving-head with 200 W COB LED and extensive features





Colleagues desperately sought

Shortage of skilled workers in the event industry

For two years, the event industry was flat. Many companies closed (temporarily), employees went on short-time work or left the industry and switched to other professions. It was also simply not possible to train new skilled workers during this period. In the summer of 2022, now that events are possible again, a gaping hole between needed and available workers is apparent. In June 2022, for example, even festivals had to be canceled at extremely short notice (when visitors were already on site) due to a lack of security personnel.

The fact that many of those who have left the industry are not coming back is partly due to the comparatively poor conditions: Physically demanding work at unpleasant hours is normal in the industry, often compounded in the past by below-average pay. Those who have found a desk job that suits them in the past two years will stick with it. On the other hand, the events industry is just one of the many sectors struggling with a shortage of skilled workers: the general lack of qualified workers is now also becoming apparent in the catering, care, tourism and other areas. There are problems in finding young talent. Experts

therefore speak of the need to significantly improve working conditions in the event sector.

Professor Bernd Schabbing teaches event management at the International School of Management. According to him, the problems are homemade: "The industry urgently needs

"The industry urgently needs to get rid of its poor image as an employer - and customers must be prepared to pay marketable prices for the services provided by the event industry."

Professor Bernd Schabbing,
International School of Management

to get rid of its poor image as an employer - and customers must be prepared to pay marketable prices for the services provided by the event industry," he commented at the Prolight+Sound 2022 trade fair. "There are also still too many employers who have not realized that they must also adapt to the expectations of potential employees [...]."

But even if working conditions are designed to be as employee-friendly as possible, potential professionals are thinking twice about entering the industry at this point in time: after all, there remains some residual risk that pandemic-related restrictions will continue to hit the event trade in the years to come. What drives those who take the plunge anyway? Mostly a genuine passion for music. The joie de vivre that comes with successful events. And the desire to enchant people again and again with bombastic experiences.



Three questions to Jochen Habermann, company VERANTEC

Do you experience the shortage of skilled workers in your own company?

Yes, even very massively. Many freelance technicians have unfortunately left the industry during Corona and apparently are not coming back. Helpers or temporary staff currently have to be recruited and trained again. I think the problem in our branch will persist for a few more years.

How does the shortage of skilled workers manifest itself in concrete terms?

You have to send a lot more inquiries to technicians in order to get a commitment. In the meantime, we are already looking for personnel when we make an offer and not, as in the past, when we receive an order. When it comes to helpers, I think the problem is even more glaring: Now, for a wide variety of reasons, not even the booked number gets to the construction site.

What are you doing to find new employees?

We're trying to find new employees through social media and with job counselors at the employment agency. But, as we all know in the industry, for us the job is more of a calling.



Hooks and clamps: Attachment equipment in event technology

If someone is not familiar with the event industry, they often raise an eyebrow when they hear the term “slings”. It refers to a variety of accessories that are used to properly attach loads in event technology, i.e. to hang or fasten them securely. These include, for example, hooks and clamps that are used to secure equipment such as moving heads to fixed structures such as trusses. In this article, we will introduce you to the most commonly used hooks and clamps.

G-Hook

This simplest form of a hook, the G-hook, is getting on in years, but still finds its places of use. G-hooks are used wherever light equipment is to be hung inexpensively and the design of the hook does not have to meet any special requirements. This hook is permitted for equipment with a dead weight of up to 15 kilograms. They are intended to be used as a sling on a 50-mm-tube, as found on most standard trusses and mounting tubes that function as load lifting devices. Smaller diameter hooks are available for smaller tubes under the search term “theater hooks”.



EUROLITE TH-50S
Theatre Clamp black or silver

Mounting hook for 50 mm tube,
maximum load WLL 15 kg



EUROLITE TH-2SC
Quick-Lock Coupler black

Mounting clamp for 13-55
mm tube incl. mini TV pin,
maximum load WLL 15 kg

Quick-Lock Hook

This particular hook scores points for its flexibility. It, too, may carry loads weighing up to 15 kilograms. The spotlight or device is attached to a special spigot that can be easily removed from the hook. Its special “claw” can include diameters from 13 mm to 55 mm, and with the help of a so-called reducer, the TH-2SC can also be attached to stand walls or other structures.

*DIN 56297

DGUV Information 215-313 (formerly BGI 810-3)

How strong a safety bond must be and how it must be attached is precisely regulated: It is made of wire rope according to DIN 12385-4:2008-6 with a nominal wire strength of at least 1770 N/mm². A safety bond must be attached in such a way that it does not allow any fall path. If a fall path is unavoidable, it must be kept as small as possible. A maximum fall path of 20 cm is permissible. A safety element that has been strained once (i.e. has started a fall) or is obviously damaged may no longer be used.



EUROLITE TPC-10 Coupler,
black or silver

Mounting coupler for 50 mm tube,
maximum load WLL 150 kg



EUROLITE TPC-50 Half Coupler
black or silver

Mounting coupler for 50 mm tube, maxi-
mum load WLL 800 kg



Bracket

This classic clamp is also called a bracket. They come in many different weight classes. Depending on the size, they can support between 150 and 800 kilograms. The advantage here is that the clamp covers the entire tube and therefore the equipment can be mounted upside down, for example. Variants with eyelets are used, among others, to “fly” sound reinforcement systems. The double clamp, where two clamps are attached to each other, allows to connect tubes or truss systems. If you want to attach a pipe to a lighting stand, there are also clamps with TV spigots for this purpose.



EUROLITE TH-250S
Quick-Lock Coupler
black or silver

PRO mounting hook,
Quick-Lock screw for
50 mm tube, maxi-
mum load WLL 250 kg

Mounting hooks

The advantages of the hook and the clamp are combined in so-called mounting hooks such as the TH-250. With these, as with the G-hook, you can first hang the device securely. One then encloses the entire tube and can thus mount overhead. These mounting hooks are also available in different weight classes; a version for the tube of a deco truss with a 35 mm diameter is also available.

EUROLITE
Safety bond
UNV

Safety bond in
accordance with
DIN 56297*,
with undetach-
able connector

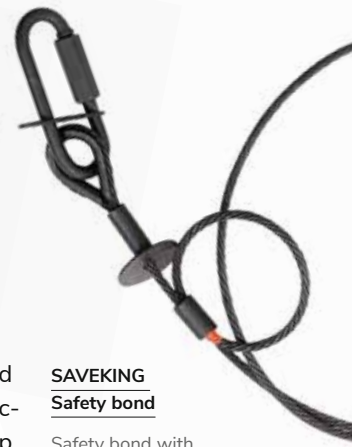

Safety bond

Except for a few special cases, every load above people must be secured with a secondary safety device. If the hook or clamp serves as a regular sling, the secondary securing is usually done by a safety bond, also called “safety”. This must be attached to the device, usually to a special eyelet, and then fastened to the supporting structure in such a way that it cannot come loose independently. It is important that only tested safety bonds are approved. These must have some special features, such as a thimble on both sides and a connecting link that cannot open accidentally. The fall distance should be kept as small as possible. These safety bonds are also commercially available with different lengths and permissible loads.

SAVEKING
Safety bond

Safety bond with
integrated drop
damping. This
solution signifi-
cantly reduces the
mechanical impulse
in the event of a
fault. The loop
reduces the load on
the breakpoint and
the secured device.
A displaced color
marking on the
loop indicates that
the rope must be
disposed of.



To attach loads and fasten them properly, you also need other accessories such as chains, shackles, round slings (with and without steel core), beam clamps, chain hoists, wire rope holders and more. Those who value safety should turn to suppliers such as EUROLITE: Internal and external inspections at every receipt of goods guarantee the highest level of safety.



TAKE IT EASY

NEW SHOW VERSIONS FOR THE EUROLITE EASY SHOW

The EUROLITE Easy Show is a controller that offers pre-programmed shows for many EUROLITE fixtures. 12 pre-installed color moods and 24 shows play with over 200 different fixtures from EUROLITE. This is ideal for beginners and users without much experience in lighting control. The shows are on a USB stick that comes with the controller. However, there is a disadvantage to this concept: you can not flexibly create new devices and thus expand the library. But since the Easy Show has been released, EUROLITE brought many new KLS systems, lighting effects, and moving heads to the market, which had not been included in the original shows. Therefore, there are now two new, additional show versions from EUROLITE EASY SHOW. So in total, there are now three versions available: Version 1 comes with the Easy Show and includes 18 KLS systems, various color mixing fixtures, many lighting effects, and 13

moving lights. In total, there are more than 200 different EUROLITE fixtures that can be used here. The two new versions now incorporate even more KLS systems, including the newer KLS. Show version 2 also offers 9 different lighting effects and 8 different moving lights. In Show version 3, fewer effects but more moving lights have been included. The new Show versions can be downloaded free of charge to a USB stick at www.eurolite.de and then installed on the Easy Show.

The shows are always stored on a USB stick (which is included in the delivery) and are selected via the "Upload/Data" USB socket. The other USB socket can be used for the EUROLITE wireless QuickDMX system.



The shows are **ALWAYS** stored on a USB stick (included). This way you can easily create different setups or make a backup copy from the drawer. The other USB socket is for the wireless QuickDMX system from EUROLITE.

V1 V2 V3

KLS SYSTEMS:

	Show V1	Show V2	Show V3
KLS 200	✓	✓	✓
KLS 400	✓	✓	✓
KLS 401	✓	✓	✓
KLS 800	✓	✓	✓
KLS 1001	✓	✓	✓
KLS 30	✓	✓	✓
KLS 120	✓	✓	✓
KLS 120 FX	X	✓	✓
KLS 120 FX II	X	✓	✓
KLS 2001	✓	-	-
KLS 2500	✓	-	-
KLS 902	✓	✓	✓
KLS 3002	✓	✓	✓
KLS Party	✓	-	-
KLS 170	✓	✓	✓
KLS 180	✓	✓	✓
KLS 190	✓	✓	✓
KLS Laser Bar	✓	✓	✓
KLS Laser Bar Pro	✓	✓	✓
KLS Next FX	✓	✓	✓
KLS Next Scan FX	-	✓	✓

SIMPLE LED SPOTS WITH COLOR MIXTURE:

	Show V1	Show V2	Show V3
RGB (TCL)	✓	✓	✓
RGBW (QCL)	✓	✓	✓
RGB WW	-	✓	✓
RGB UV	-	✓	✓
RGBWA UV (HCL)	✓	✓	✓
RGB W WW A UV (SCL)	✓	✓	✓

SCANNER

	Show V1	Show V2	Show V3
TSL 150	✓	✓	✓
TSL 200	✓	✓	✓
TSL 1000	-	✓	✓
KLS Duo Scan	-	-	✓

LIGHT EFFECTS:

	Show V1	Show V2	Show V3
B40 HCL	✓	✓	✓
B40 Laser (weiß)	✓	-	✓
BR 60	-	✓	-
D2000	-	✓	-
FE 2500 Hypno	✓	-	-
FE 1750	✓	-	-
Laser Derby	✓	-	-
WF-30	-	-	-
WF-40	-	✓	-
FE-700	✓	✓	-
Z-1000	✓	✓	-
Mini D-20	✓	-	-
Gobo Derby	✓	-	-
Super Strobe ABL	✓	-	-
CBT-6	✓	-	-
Laser Derby MK 2	-	✓	-
D-30	-	✓	-
D4000	-	✓	-
Z 4000	-	✓	-

MOVING HEADS

	Show V1	Show V2	Show V3
TMH 75	✓	-	-
TMH 60	✓	-	-
TMH 60 MK 2	✓	-	-
TMH 30	✓	-	-
TMH 30 MK2	✓	-	-
TMH 17	✓	✓	✓
TMH 13	✓	✓	✓
TMH 46	✓	✓	✓
TMH W 36	✓	✓	✓
TMH W 63	-	-	-
TMH X4	-	-	-
TMH S30	✓	✓	✓
TMH S90	✓	✓	✓
TMH H90	-	-	✓
TMH B90	-	-	✓



BLACK LIGHT?

Everything about UV light and its use

“Blacklight” sounds something like squaring the circle. Because what is black cannot be light. And yet, the term is very apt: When we talk about black light, we are referring to ultraviolet radiation in the frequency range 315 nm to 380 nm. This is also called UV-A radiation or “near UV light”.

The radiation itself is not visible to the human eye, but objects illuminated with it glow - provided they are UV-active. This means that the illuminated objects contain substances that react to the UV light and glow on their own. The black light therefore glows.

Discharge lamps offer one way of generating black light. These can be in tube form, similar to a fluorescent lamp, or bulb form. This type of black light has the great advantage that it produces “true” black light in the frequency range of 365 nm. This is outside the range of light visible to the human eye; therefore, only the UV-active materials that are illuminated are really visible. Another plus point is that black light tubes in particular are inexpensive to obtain. The disadvantage, however, is that this type of UV generation cannot be easily controlled by DMX signal and thus cannot be easily integrated into a show.

Enormously powerful UV lamp, also suitable for longer distances



EUROLITE Black Gun UV-spot for E-40/400W

Black light housing with narrow beam for E-40/400 W UV lamp

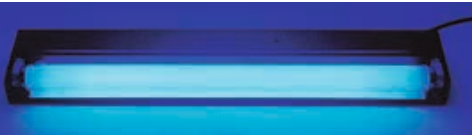

EUROLITE UV Complete Fixture 60cm 18W metal

Complete set with UV tube

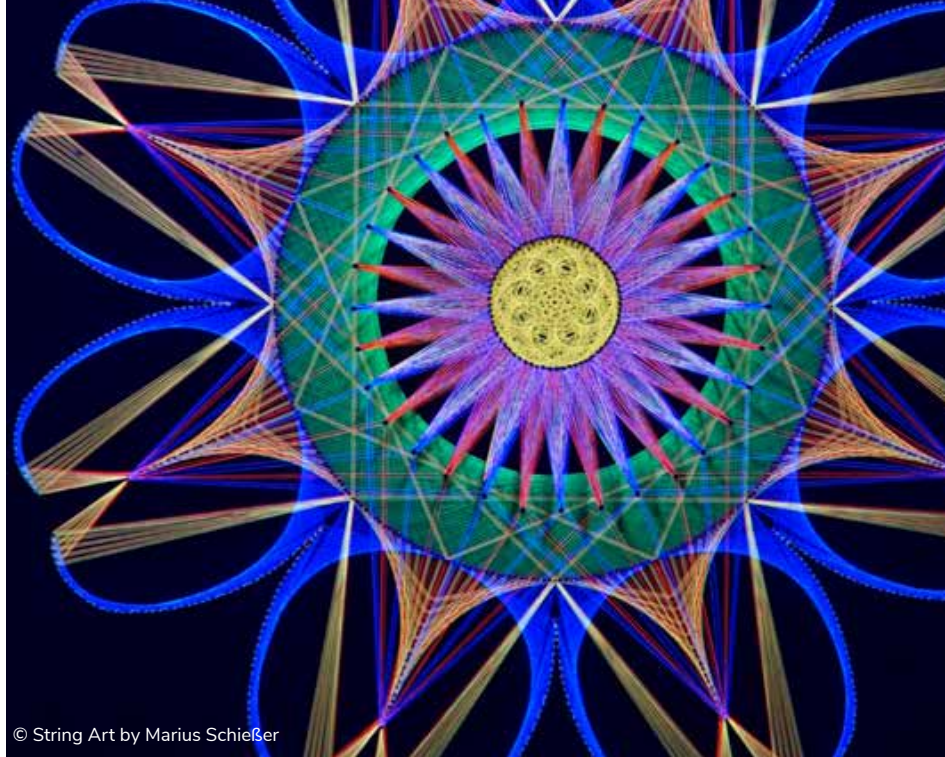

© String Art by Marius Schießler

Alternatives that can be controlled via DMX can be found in the field of LEDs. Here, too, there are now many black light solutions: As stand-alone UV devices, but also as part of colorful fixtures that can generate UV light in addition to color mixing. However, most UV LEDs produce light with a slightly different wavelength than the UV discharge lamps: UV LEDs are mostly at 380 nm to 400 nm, more in the visible range. The result of this shifted wavelength is that while it produces both a black light effect, it also produces a lot of visible light. This can be an advantage or a disadvantage. An advantage is when visible light is also produced, especially at parties or concerts, so that the guests can orient themselves well. So you have the black light effect, which makes things glow; but there is still enough visible light to move around the room safely. The situation is different for performances where the audience is seated enjoying a show. Here, it is sometimes intentional that actors dressed in black are not seen, but only individual components of costume, decoration and scenery are illuminated. Visible residual light is not useful for this. In the meantime, LEDs that produce UV light in the range of 365 nm are available for such cases. However, these are considerably more expensive than the simpler LED variants and so far are only available in higher power classes.



EUROLITE LED PARTY UV Spot

Compact UV spotlight with 30 W COB LED and DMX control



EUROLITE LED TL-3 RGB+UV Trusslight

Variable truss light and upright with bright 3 x 7 W RGB+UV LED



EUROLITE LED IP PAR 9 UV Spot

Weatherproof (IP65) PRO UV spotlight with 9 UV LEDs (365nm), incl. IR remote control

Gaffa Tape, UV-active

For deco design and marking



EUROPALMS Kentia palm,
artificial, uv-white, 170cm

An ideal high-tech decoration

What glows under black light?

In the past, it could be assumed that all white materials glow when they are illuminated with UV light. However, since the composition of bleaching agents in fabric manufacturing and detergents has changed, not every white T-shirt is UV-active today. But nowadays many materials are intentionally made UV-active. You can get clothes, fabrics, paints and decorative materials in UV-active variants. There are also cosmetics and even tattoo inks that contain UV-active materials now. Something that is used much more frequently in event technology, however, is UV-active gaffa tape. Not only can it be used to make markings - but it can also be used for handicrafts. So nothing stands in the way of creativity when it comes to black light fun.



PROTECTION OF MINORS AT EVENTS

The protection of minors is clearly regulated by law in Germany: The Youth Protection Act, or JuSchG for short, stipulates, for example, how long young people of what age may be out in public unaccompanied by adults, who is liable for compliance with the regulations and which drinks may be served to young people. Violations of the Youth Protection Act are severely punished - so event organizers should always keep the important directives in mind. We have compiled a list of these guidelines and who is responsible for complying with them:

AGE

The JuSchG clearly regulates under which conditions young people are allowed to be at events and for how long.

(1) Children and adolescents under the age of 16 may not be present at public dance events without the accompaniment of a custodian or guardian and adolescents over the age of 16 (without supervision) may only be present until midnight at the latest.

(2) As an exception to paragraph 1, children may be present until 10 p.m. and adolescents under 16 until midnight if the dance event is organized by a recognized youth welfare organization or serves artistic activities or the preservation of customs.

(3) The competent authority may approve exceptions.

This paragraph makes it clear that the law makes a distinction between young people under and over 16 years of age. Thus, young people under the age of 16 are generally not allowed at public dance events; between the ages of 16 and 18, young people are allowed to be there until midnight. The situation is different for events that are officially organized by a "recognized youth welfare organization," for example a religious community or an association such as the Red Cross. In this case, children under 14 are allowed to stay until 10 p.m., and young people between 14 and 16 until midnight.

The commercial organizer is responsible for monitoring and complying with youth protection regulations. He can also be prosecuted for violations of the JuSchG.

ALCOHOL

When it comes to alcohol, the law also clearly stipulates what is permitted:

(1) In restaurants, points of sale or otherwise in public, it is not permitted to give

1. Beer, wine, wine-like beverages or sparkling wine or mixtures of the said beverages with non-alcoholic refreshments to children and adolescents under 16 years of age,
2. Other alcoholic beverages or foodstuffs containing other alcoholic beverages in not only negligible quantities to children and adolescents.

nor may they be permitted to consume them.

(2) Paragraph 1 No. 1 shall not apply if adolescents are accompanied by a person with parental authority.

Thus, as long as the adolescents are out and about without their legal guardians, they may not be handed any alcoholic beverages or food. By the way, this also applies if the child is supposed to get the beer at the bar "for dad" or "for uncle." Young people over the age of 16 are allowed to drink beer and wine as well as mixed drinks made from them. Only after the age of 18 is the consumption of "stronger" alcohol such as liquor and cocktails permitted.





TOBACCO AND NICOTINE

Adolescents are also prohibited from smoking - until their 18th birthday:

(1) Tobacco products and other nicotine-containing products and their packaging may not be distributed to children or adolescents in restaurants, points of sale or otherwise in public, nor may they be permitted to smoke or consume nicotine-containing products.

This also applies without exception to shishas and e-cigarettes, even the nicotine-free variants.

In the event of violations of the Youth Protection Act, the organizer faces severe penalties: from fines to revocation of the business license.

In addition to the Youth Protection Act, the Youth Employment Protection Act is also important in the event industry. It applies to children and young people under 18 and regulates exactly how long, when and under what conditions young people may work. For example, underage event technician trainees cannot supervise concerts that last longer than 10 pm. In addition, stricter rest periods must be observed than for adult employees.



Voxel mapping in 3D with MADRIX 5 and vertical 360° LED tubes at the project "Cymatiks" in Brussels. Many thanks to CG Services and Stefano Cazzulo from Trussdesign.it.



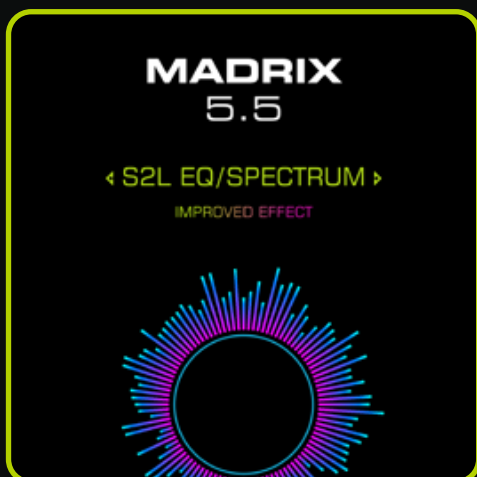

MADRIX 5.5

Major software update now available

MADRIX 5 is the LED control solution for pixel-based LED projects. The team at inoage is pleased to present MADRIX 5.5, one of the biggest updates in recent years.

Highlights include:

MIDI feedback

By lighting up the controller, there is now visual feedback that contributes to better clarity.

Timelines

Timelines enable a new way of working. Fascinating light shows can now be synchronized to music even more easily. Based on time-code, sequences can be created and triggered at exactly the right moment. The audio track is displayed in waveform. MADRIX 5.5 can thus also become a time-code transmitter.

Performance

MADRIX 5.5 offers completely new possibilities in terms of performance: Lighting plans with large gaps between lighting profiles benefit enormously from this.

Licensing system

The maximum available resolution for output via DVI has been increased for the following licenses:

- **MADRIX 5 start:** From 4,096 (64 x 64) to 16,384 (128 x 128)
- **MADRIX 5 entry:** From 16,384 (128 x 128) to 264,144 (512 x 512)
- **MADRIX 5 basic:** From 264,144 (512 x 512) to 1,048,576 (1024 x 1024)
- **MADRIX 5 professional:** From 1,048,576 (1024 x 1024) to 2,097,152 (2048 x 1024)

S2L EQ / Spectrum

For many users, this function is one of the most important in MADRIX: Equipped with new parameters, it is now even more fun to use the live Sound2Light effect.

MADRIX 5.5 includes many more improvements. It is available as a free update for MADRIX 5 and can also be downloaded as a demo version from www.madrix.com.



EUROLITE AKKU Bar-6 QCL

Battery LED bar with 4in1 LEDs and IR remote control



WINE PRESENTATION // SPREMBERG CASTLE

On June 18th, 2022 a wine presentation of the special kind took place in the castle Spremberg. Winemaker Julia Schittler presented her new wines that evening. The historical backdrop was stylishly staged with the logo colors of the winery. Pentatone Music from Spremberg was responsible for the technical realization of the event. Around 40 EUROLITE devices were used, including AKKU Bar-6 QCL, AKKU IP UP-4 PLUS, LED TMH-S200 and LED TMH-60 MK2.



EUROLITE LED TMH-60 MK2
Moving-Head Spot COB

Powerful spotlight with 60-W LED, 2 gobo wheels, color wheel and prism



EUROLITE AKKU IP UP-4 Plus HCL
Spot WDMX

IP65 uplight with replaceable battery, RGBWA+UV LEDs, WDMX and IR remote control



EUROLITE LED TMH-S200
Moving-Head Spot

LED Moving Head spot with color wheel, static & rot. gobo wheel, prism, frost, focus and zoom.



Dirk from
Pentatone Music

LEaT Jobs
Der Stellenmarkt der Entertainment Industrie

ES GEHT NICHT UM EINEN JOB.
ES GEHT UM DEINEN JOB!

JETZT
TRAUMJOB
FINDEN!



jobs.leadcon.com

LIFESTYLE TREND HYGGE

The term “hygge” has its roots in Scandinavia and is primarily associated with the Danish lifestyle. It is best described as a feeling of warmth, coziness, and security. Not only in your own four walls but also in vacation homes, hotels, or restaurants, it plays a major role in designing and decorating rooms beautifully for the long term. This creates an all-around positive feeling - a feel-good ambiance - for guests and visitors. They feel comfortable and like to come back again and again, and that is exactly HYGGE. With a few simple basic rules, you can also make your premises “hyggelig”:



More than just dried plants:

The fluffy pampas grass stalks are a long-lasting and low-maintenance alternative to fresh flowers. Their natural hues harmonize perfectly with any interior design style.

TIP: Impregnating with hairspray counteracts “lint”, so you can enjoy the natural decoration for a long time.

JOLIPA Pampas grass straw bunch, dried, natur, 75cm

Dried natural stalks of pampas grass in a bundle





TIPS FOR HYGGE

1

Country style with modern elements

2

Color palette:
blue and grey tones,
beige, white, natural
shades

3

Dried flowers and
artificial plants as
decorative elements

4

Indirect lighting
(warm white LEDs)
and candles



With its large, shiny green leaves, the “window leaf” is not only one of the most popular houseplants. With the artificial plant, you can also effortlessly set green accents.

EUROPALMS Monstera deliciosa, artificial plant, 90cm

Monstera plant suited for outdoors



EUROPALMS Split philo plant, artificial, 38cm

Split philodendron with leaves made of high-quality PEVA

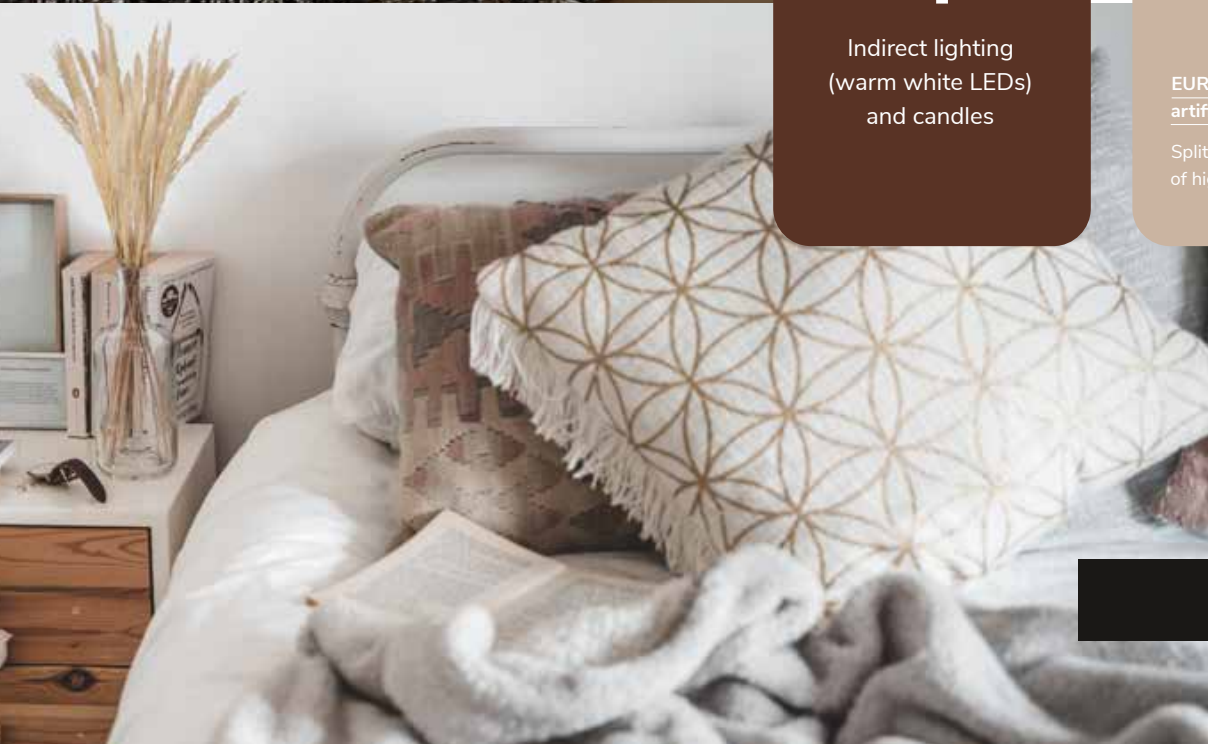

HYGGE THROUGHOUT THE HOUSE

Whether living room, dining room, study or bedroom - for all rooms you will find the right hygge accessory!



The eye-catching, dried natural grass branch spreads a simple yet elegant atmosphere. Whether incorporated into arrangements or as a fluffy soloist in a large vase, it always comes off perfectly.

JOLIPA Pampas grass branch, dried, natural, 137cm

Dried natural branch of pampas grass

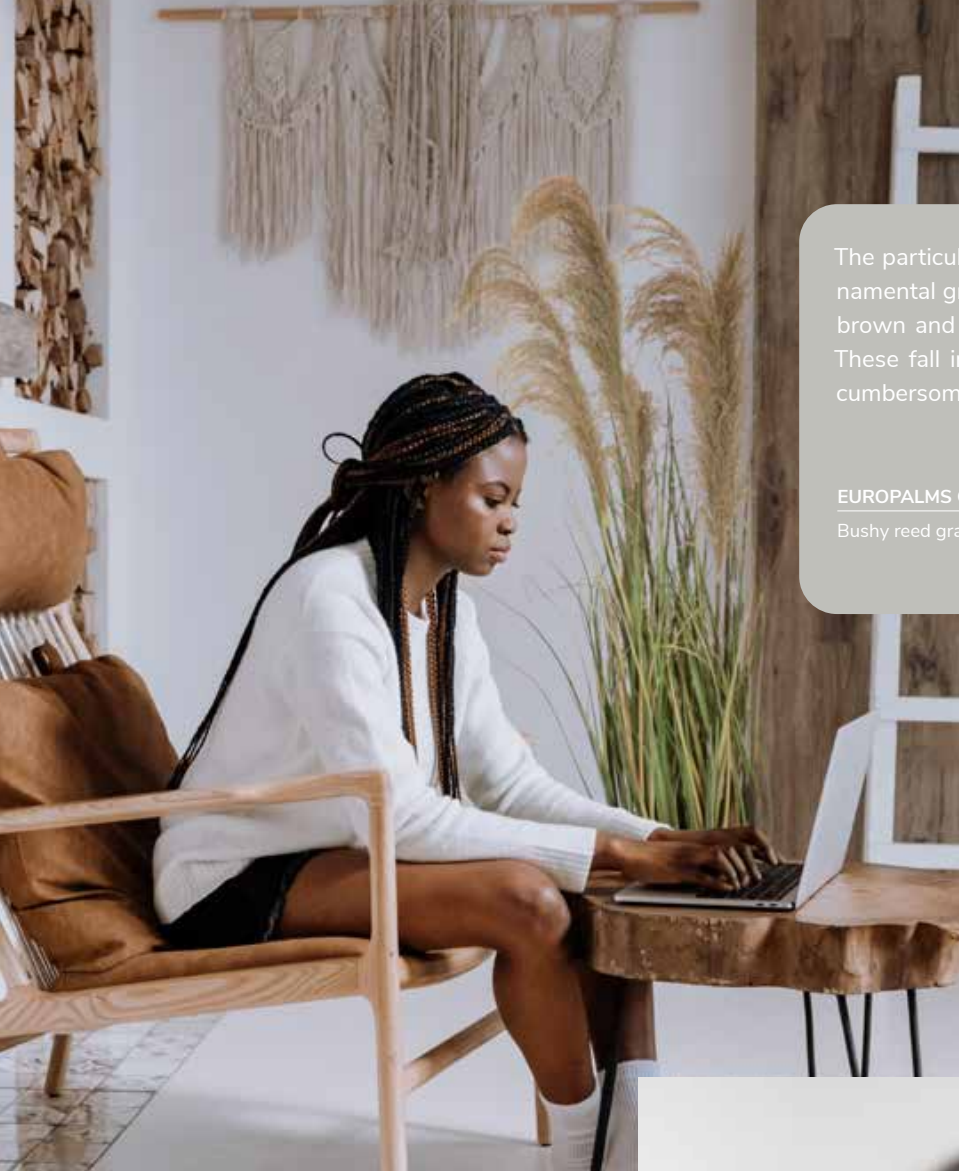

The particularly lively appearance of the ornamental grass is achieved by the different brown and green tones of the slim leaves. These fall into place by themselves and a cumbersome styling is not necessary.

EUROPALMS Chinese silvergrass, artificial
Bushy reed grass for individual, natural decorations



A stylish and cozy feel-good atmosphere can be created in no time at all with floral light accents.

EUROPALMS Heather twine, with LEDs, white, 180cm

Decorative twig with LEDs



Hygge also means to consciously take time - for things that often come up short in the hustle and bustle of everyday life. Especially in the dark and cold season, it is important to create oases of well-being to recharge your batteries. Appropriate decoration elements support this positively. Cuddly blankets, fluffy socks, and a hot chocolate may not be missing! This way, you're all set for a relaxing evening with friends or family.





EUROPALMS
Artichoke Branch
(EVA), artificial, beige,
100cm

Decorative stem for
your autumn deco-
ration

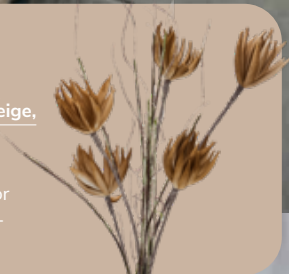

Dried flowers and artificial, decorative branches present themselves from their most beautiful side permanently - in contrast to fresh flowers. Arranged both as soloists in a large vase or draped on a sideboard, they form a beautiful seasonal eye-catcher. With a few simple steps, they can also be incorporated into existing arrangements and flexibly replaced again. Especially well suited for the hygge style are warm brown tones, reminiscent of autumnal colored leaves.



The artificial flowering branches from EUROPALMS convince with a surprisingly realistic look, natural color gradient, pleasant feel and high aging resistance.

EUROPALMS Owl Feather Branch (EVA),
artificial, 110cm

Decorative twig whose leaves look astonish-
ingly similar to owl feathers



Künstler-Magazin

Fachmagazin für die Show- und Eventbranche

Jetzt die aktuelle Ausgabe online lesen unter:

www.gedu.com

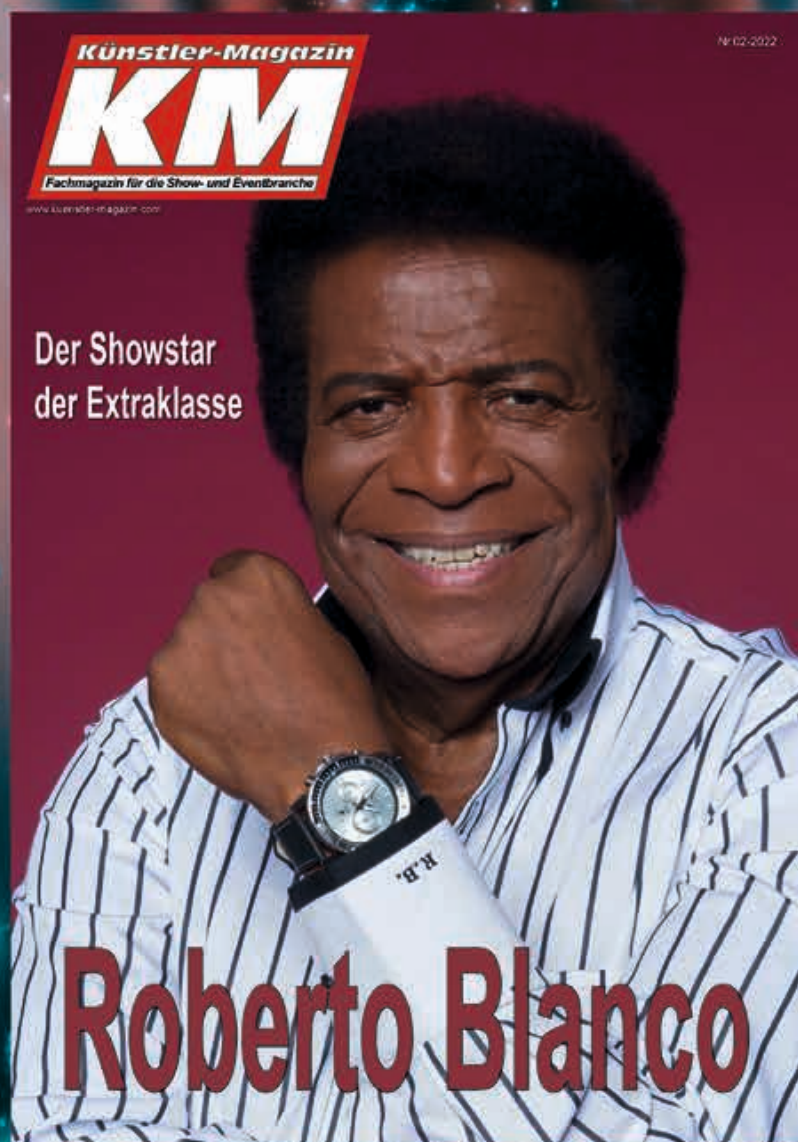

Tipps, Trends, News und Videos



Künstler-Katalog als
eKatalog lesen unter:
www.gedu.com





HOW TO SPOOKIFY

Less is more - this motto does not apply to Halloween. Here, the decoration can be a little more, because no occasion is better suited for decorations and disguises, which may also be really scary.

Why not simply transform an entire room into a frighteningly beautiful chamber of horrors? With a few simple steps, the dining room becomes the perfect ghost and pirate haunt. This includes not only the decorating classics like pumpkins, spiders and spider webs, but also a wide variety of decorative figures and accessories. Starting from talking murals to skele-

tons and animated ghostly creatures that have already taken a seat at the dining table. For an absolute stage setting, the scene can be completed with yellowed curtains and large-scale styrofoam panels, which were previously patinated with dark colors. This will create a "scuffed" look. If now mysterious fog clouds move through the room, the creepy effect is perfect. In addition, the spooky backdrop can be staged with UV light and lighting effects.

TIP: A wonderful Halloween buffet could also be eerily arranged on the dining table.



EUROLITE Set N-10 silver + B2D
Basic smoke fluid 1I

Compact 400 W fog machine with cable remote control



1 EUROPALMS Halloween Pirate, 170cm

Hanging figure pirate

2 EUROPALMS Halloween Figure Wanderer, 160cm

Standing figure: animated skeleton

3 EUROPALMS Halloween Skeleton, 150 cm

Hanging figure skeleton

4 EUROPALMS Halloween Costume Witch Hat with Spider

Spider witch hat with integrated headband

5 EUROPALMS Halloween Table Deco, Roses, 28cm

Extravagant floral decoration in Gothic style

6 EUROPALMS Halloween Witch, white, 170x50x20cm

Animated figure with light, sound and motion effects

7 EUROPALMS Halloween Figure Monk, animated, 170cm

Animated skeleton man as a standing figure

8 EUROPALMS Halloween Figure Death Man, 68cm

Standing figure godfather death, animated

9 EUROPALMS Halloween Black Angel, 175x100x66cm

Standing figure: reaper with light, sound and motion effects

10 EUROPALMS Halloween Horror Rabbit, 140x30x15cm

Animated figure with light, sound and motion effects

11 EUROPALMS Halloween Zombie Theo, 67cm

Animated zombie torso with light, sound and motion effects

12 EUROPALMS Halloween Pumpkin in Spider Web, 25cm

Woven pumpkin for hanging or lying

13 EUROPALMS Halloween Groundbreaker Mummy, animated 40cm

Animated zombie torso with light, sound and motion effects

14 EUROPALMS Halloween Pirate Box, 32x48x32cm

Animated chest with light, sound and motion effects

15 EUROPALMS Lantern Cat, 23cm

Lantern with cat motif

16 EUROPALMS Deco fabric, fine, white, 165x400cm

Versatile addition for your decoration

ENTERTAINMENT TECHNOLOGY ON A GLOBAL SCALE



mondodr.com | tpimagazine.com | tpmeamagazine.com | mondodrawards.com | tpiawards.com | tpmeaawards.com



MONDIALEMEDIA LTD





ASK

DOC FOG!

Questions and answers about fog
and fog fluid in event technology

Questions and myths about fog and fog fluid are always popping up. We want to bring some clarity into the haze and therefore take a look at the most frequently asked questions using the example of the manufacturer EUROLITE.

Is fog dangerous?

No. All EUROLITE fluids are developed and manufactured in Germany. They are subject to regular quality control. A fundamentally dangerous substance is therefore excluded from this side. Nevertheless, many singers or clubbers have the feeling that they get a dry throat from the fog. This can be explained by the fact that artificial fog binds humidity in the air. The more fog in the room, the drier the air - and that affects the voice. Drinking plenty of water can help. But you can also spray around the stage again and again with a flower sprayer to increase the humidity again.



How to store a fog machine properly?

Fog machines should never be stored for several months with fluid in the system. If the machine is not going to be used for a long period of time, empty the fluid container and fill it with about half a liter of distilled water instead. This is then nebulized in the machine so that the hoses and nozzles are free of fluid residues. Otherwise, these would dry out over time and leave residues in the machine.

Is it normal to smell something burning?

No. You should be careful if the fog smells burnt. If a distinctly unpleasant odor is noticeable, this may indicate a defective machine that may be vaporizing the fluid too hot. Thereby parts of the fluid are burned and then fog can be really dangerous to health. In this case: Take the machine out of operation and have it checked by the manufacturer or specialist dealer!

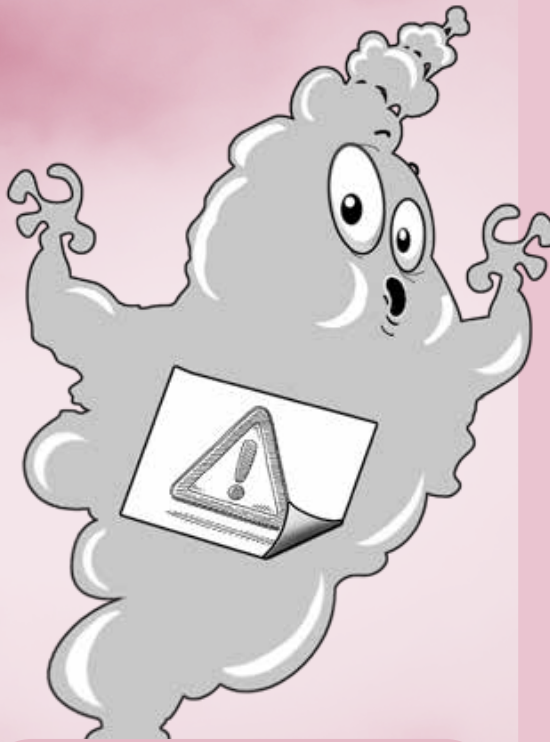

Why are there warnings on my fog fluid?

Some fog fluids have had warning symbols printed on them for a few years, while others do not. This is due to a substance called diethylene glycol (DEG). DEG has been subject to mandatory labeling in the EU since 2014. Hazardous concentrations are not reached during fogging, but labeling is still required. Users now have a free choice of fluids with and without DEG. With the additional designation -2D, EUROLITE also offers an alternative that does not contain diethylene glycol.

What are the different fluids?

There are different fluids from EUROLITE, which are marked with letters:



A-Fluid: The A-Fluid is the simplest and least expensive of the fluids at EUROLITE. It is ideal for smaller, less expensive machines and smaller areas such as party rooms. The service life, i.e. how long the fog stands in the room until it dissipates again, is relatively short.



B-Fluid: The B-Fluid has a higher density and service life than the A-Fluid. It is very popular in small and medium-sized clubs.



C-Fluid: The C-Fluid has a medium lifetime and density and is ideal for medium-sized rooms.



P-Fluid: P stands for professional. This fluid is higher quality than A, B & C fluid and has a long lifetime with medium fog density. This fluid is ideal for higher quality fog machines as it allows for a very long life of the machine even with frequent use.



E-Fluid: It becomes extreme with the E-Fluid. This is very dense and also stands for a very long time in the room. Not only large discotheques and stages are the ideal area of application, but this fluid is also popular for fire simulations at the fire department and for leak tests.



X-Fluid: X is the enhancement of E. This fluid offers the highest density and longest service life of all EUROLITE fluids.



DSA: This fluid is also very high quality, but dissolves very quickly. Therefore, it is ideal for special effects and fog fountains, such as those created by EUROLITE's NSF machines (vertical foggers).



Hazerfluid D-5: This fluid is an oil-based fluid and creates a very fine, durable haze in the appropriate hazers. Note: not every hazer will work with oil-based fluid. If the wrong machine is filled with oil-based fluid, it will spray out boiling hot droplets of oil. So before using this fluid, you should definitely make sure that it is an oil-based machine.

Watch the video!





The topic of sustainability is on everyone's lips and is slowly but surely gaining a firm foothold in the event industry as well. Especially when it comes to electronic equipment, the following therefore applies: Reuse, repair, recycle! Some manufacturers are setting a good example and offer a plethora of spare parts, thanks to which broken devices are quickly as good as new again.

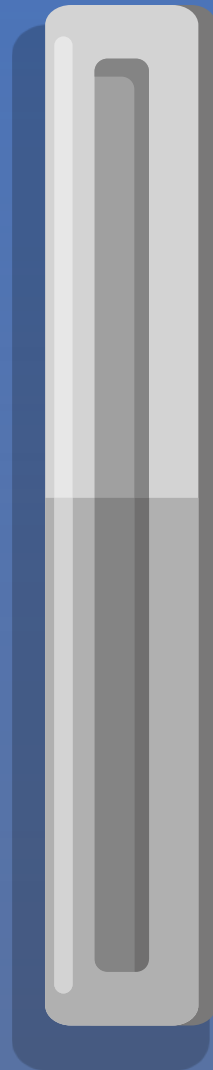

FIXIT!

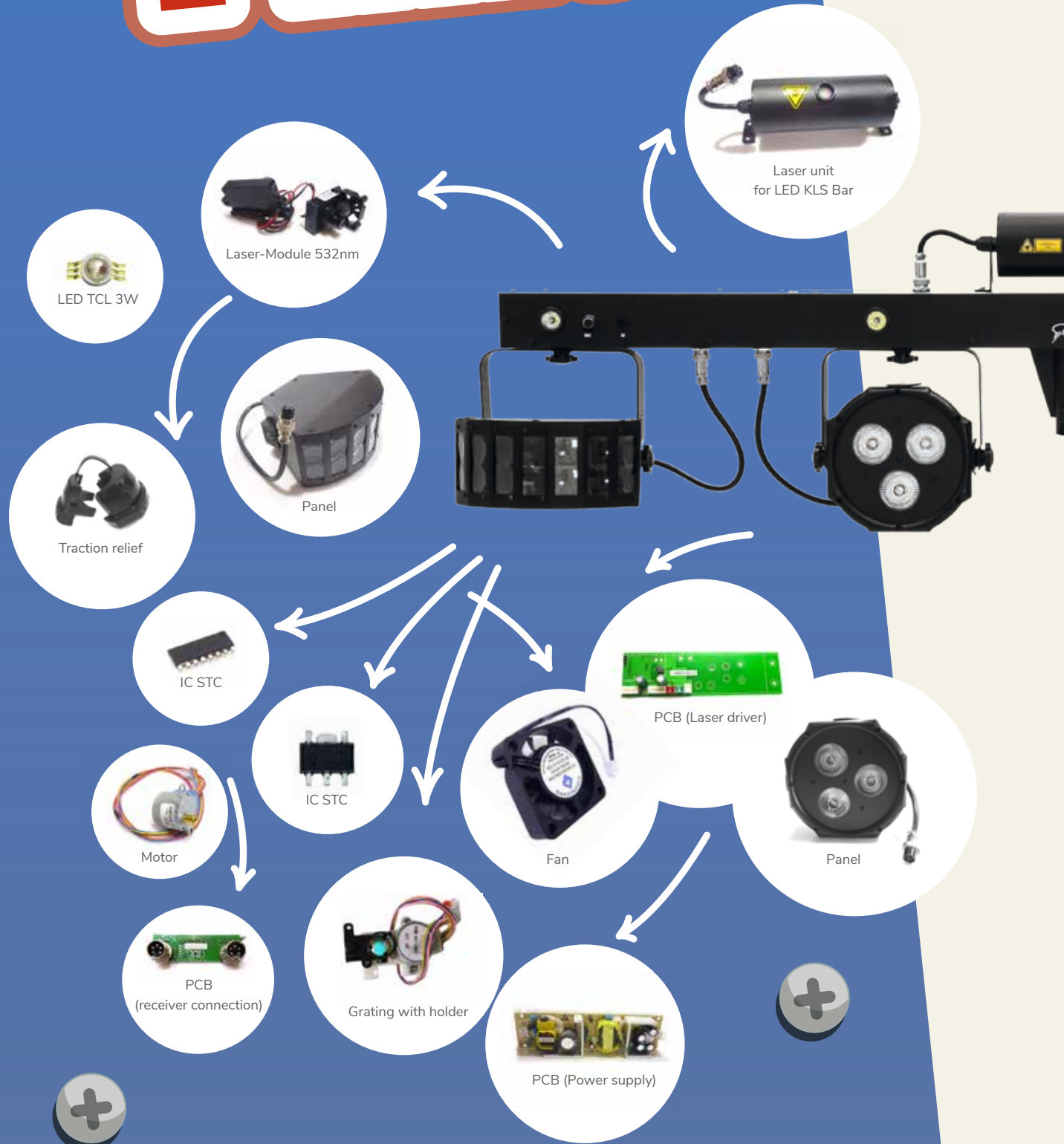

FIX IT!

Oops, there it is: A moment of carelessness, a jostle, and a device is broken. But that doesn't mean you have to throw it away.

Repair instead of throwing away: If something breaks in an electrical appliance, it is often worthwhile to repair the product and get it working again with the help of a replacement part. In the spirit of sustainability, many manufacturers in event technology offer spare parts for lighting and sound products. Taking a EUROLITE LED KLS Laser Bar FX and an OMNITRONIC TRM-202 MK3 as examples, let's take a look at which spare parts are available in each case.

10 YEARS

Even after a device has been taken out of the current range and is no longer available, the spare parts for this product are often still available. For many items, EUROLITE still stocks the spare parts ten years after the unit has been discontinued from the range.

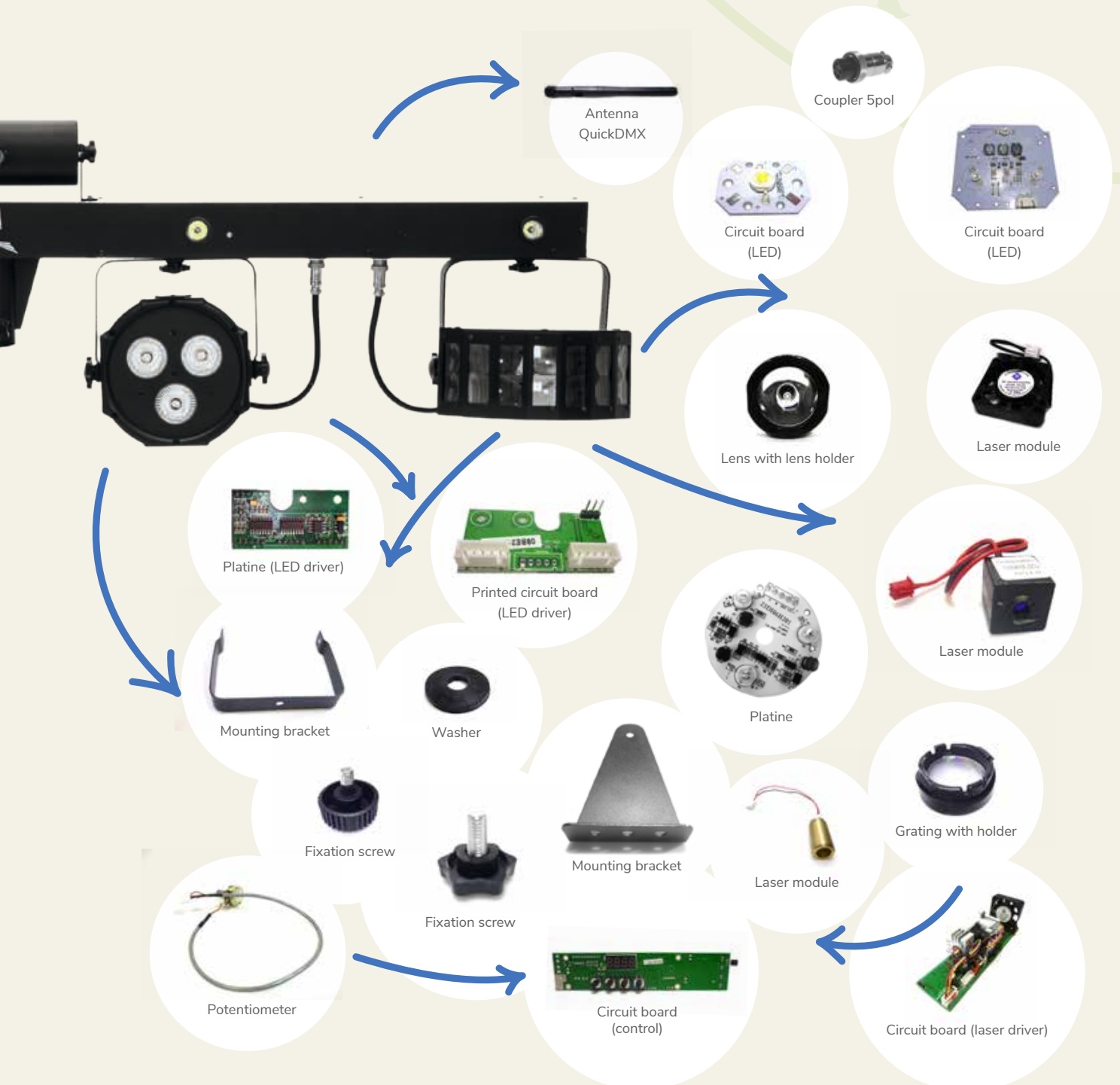

Reducing e-waste

According to The Global E-waste Monitor, over 50 million tons of e-waste were generated worldwide in 2020 alone; in Germany, each citizen produces an average of 19.4 kg of such waste per year (source: statista.de). The problem with this is that, unfortunately, only about 20 percent of the e-waste generated is recycled properly. 80 percent of it ends up in residual waste or in African landfills, where toxins are released during incineration and end up in the environment. Often, however, this is not even necessary: Repairing a device is not only financially much cheaper than buying a new one, it is also good for the environment.

Every German produces
19.4kg of electronic waste
per year

The ten countries with the
largest volume of e-waste

Jeder Deutsche produziert 19,4 kg Elektroschrott

Die zehn Länder mit dem größten
Elektroschrott-Aufkommen 2019

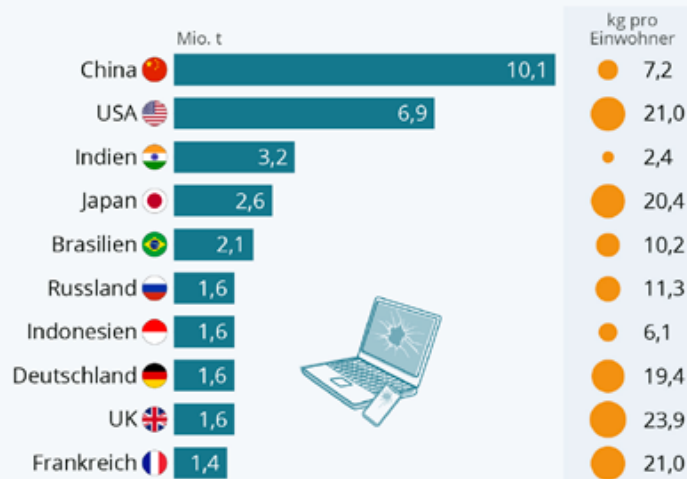

Quelle: The Global E-Waste Monitor 2020



statista



Ask the dealer or manufacturer

But how do you know whether your own defective appliance can be repaired? The easiest way is to ask the dealer from whom you bought the device. In most cases, the salesperson can immediately tell you whether the defect can be repaired right away. If this is not the case, the device is sent to the manufacturer and repaired there. In return, the customer usually receives a cost estimate and information about which parts need to be replaced. If the product can no longer be repaired, the manufacturer can dispose of it properly.



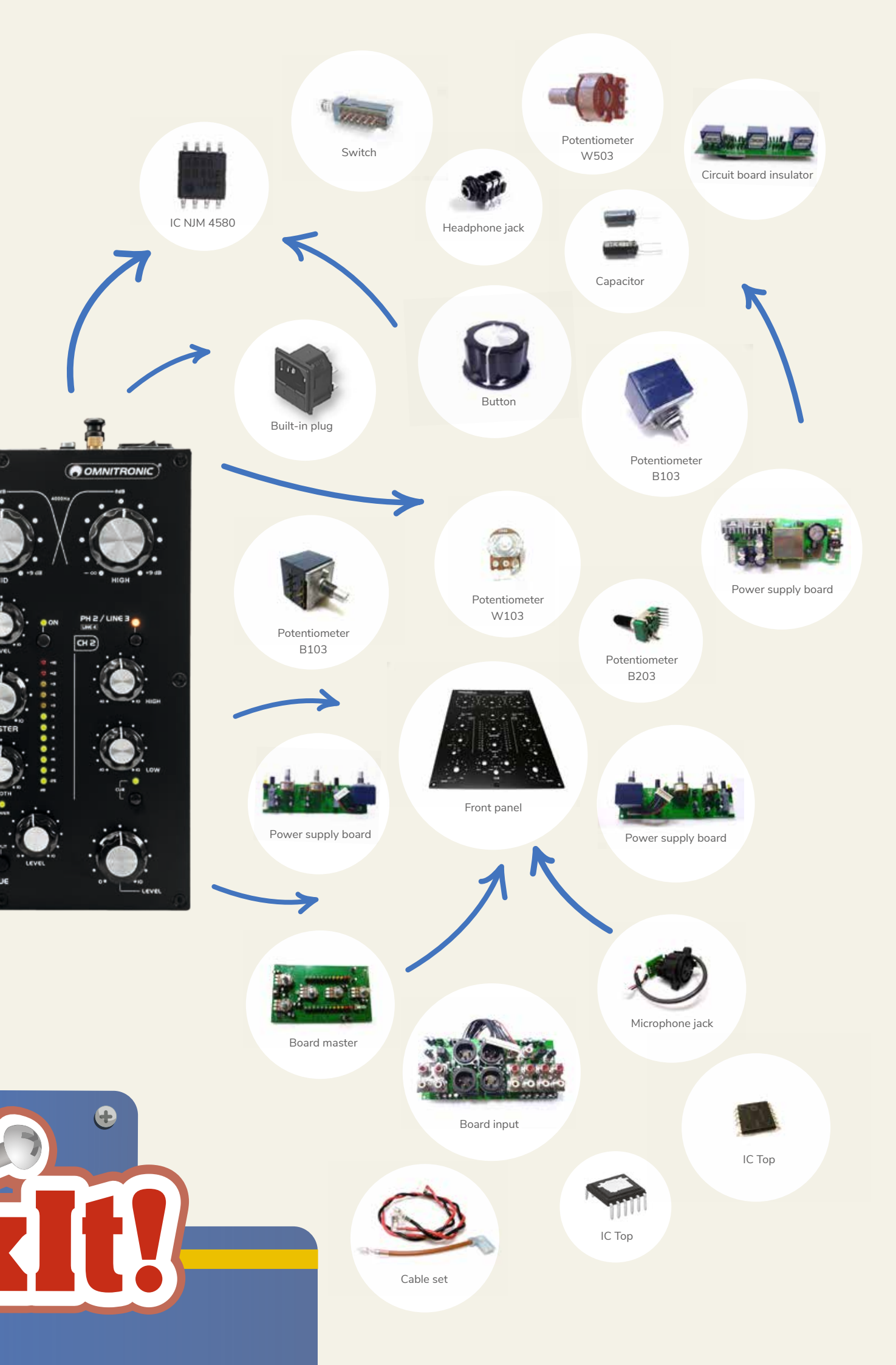

Kit!

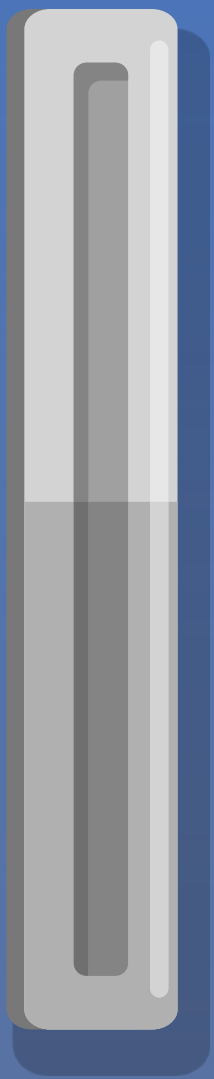

FixIt!



XIRA

OMNITRONIC XIRA-215A
Active 2-Way Speaker FIR-DSP W RMS

GALACTICALLY POWERFUL PERFORMANCE

With the new XIRA, OMNITRONIC presents a powerful speaker that also impresses with its crystal-clear sound. The active 2-way speaker amazes with its high and at the same time distortion-free output: With 300 watts RMS power for the woofer and 50 watts RMS for the tweeter, XIRA makes the stomach quiver.

The DSP-controlled biamp amplifier in Class D design offers four practical presets that ensure consistently good sound for any application: „MUSIC“ provides a slight bass and treble boost, „DJ“ gives the sound more presence and bass, „MONITOR“ is the right choice for use as a floor monitor and „SUB“ always fits when an additional subwoofer is used.

The visually appealing design of the low-vibration and robust cabinet also allows flexible use of the XIRA: the active speaker can be mounted on a stand or set up as a floor monitor. For tripod mounting, the box has a double flange with 0° and 5° tilt.



TECHNICAL SPECIFICATIONS

Power consumption:	Max. 400 W
Rated power:	300 W RMS LF; 50 W RMS HF
Frequency range:	40 - 20000 Hz
Sensitivity:	96 dB
Max. SPL:	121 dB
Attachment system:	Ø 35mm
Circuitry:	Class D Biamp
Connections:	Output: line via 1 x 3-pin XLR
Input channels:	1 x mono with Mic-line switch via 3-pin XLR/6.35mm jack (F) combination socket (mounting version), channel control via Rotary dial 1 x mono via 3-pin XLR/6.35mm jack (F) combination socket (mounting version), channel control via Rotary dial
Speaker:	1 x woofer (15") approx. 38 cm Voice coil compression tweeter highs (1.35") approx. 3,5 cm
Type of speaker:	Compact cabinet speaker
Type:	Vented
Dimensions:	Length: 41 cm, Width: 43 cm, Height: 70 cm
Weight:	22,00 kg



DSP-controlled biamp amplifier (class D)
Application presets for quick sound contouring:
MUSIC (slight low and high frequency boost)
DJ (increased presence and bass)
MONITOR (for use as a floor monitor)
SUB (for use with subwoofer)

Dual flange with 0° and 5° tilt angle enables flexible positioning
Applications: **standing**, as **floor monitor**, on a speaker stand or wall holder

5 TIPS for good voice recordings in the home studio

Whether it's a podcast, an audio book or a voice-over for a video: If you want to make good voice recordings in your own home studio, you should set up the available space as well as possible. Here are five tips on how you can make good quality voice recordings at home.

1) OPTIMIZE ROOM SOUND

A good room sound ensures that the voice recording sounds neither too dull nor too reverberant. For this to happen, the sound has to hit different materials. Therefore, a furnished living room is often a good basis: The existing furnishings (for example, bookshelves) can refract the sound and materials such as fabrics (sofa, cushions, curtains) reduce reverberation times. Attention: large, smooth surfaces such as windows, on which the sound just hits, increase the sound reflection and thus provide a poorer sound quality. Therefore, it makes sense to cover large windows with fabric or other soft materials, or to position the speaker facing away from them. To avoid having too much room sound on the recording, small absorber systems can be used.

2) MICROPHONE

For voice and speech recordings, large-diaphragm condenser microphones that have an unidirectional characteristic (e.g., cardioid) are well suited. In this way, primarily the speech is recorded and only a few ambient noises and interferences from the room.

3) POSITIONING

When positioning the speaker, the rule is: as close as possible to the microphone, but as far away from it as necessary to avoid transmitting wind noise. The so-called proximity effect is when the low frequencies of a voice are emphasized more strongly the closer the sound source is to the microphone. This effect can produce a good sound result if it is used in appropriate doses.

To avoid unwanted hiss and plop sounds on the recording, aids such as a pop filter can be used.

4) LISTENING SITUATION

Every new recording must first be leveled so that no annoying clipping can be heard later. In order to be able to level as optimally as possible, however, the monitoring situation must also be right: Because only if you recognize all disturbing influences and problems in the recording path as early as possible you can correct them. It is also helpful for the speakers to be able to hear themselves well.

A pair of ear-enclosing headphones with the best possible external noise attenuation ensures that you hear everything you need to hear - namely the recording - and not too much of your surroundings. If the headphones cover a particularly wide frequency range, all the better: that way, even details don't get lost. To make working as comfortable as possible, the headphones should also have a comfortable fit and be well-padded on the ears.

5) MONITORS

Once the recording is made, it's usually on to post-processing. Compressors, EQ and de-essers are used to optimize the recording. To ensure that you don't miss anything during this process, it is advisable to place the monitor speakers at ear level and to ensure an undisturbed sound path between the monitor and the ear. For this reason, it often makes sense for home studios to place the monitor boxes on the desk with the help of table monitor stands. Thanks to the table stands, the monitors can stand slightly elevated on the one hand and thus improve the monitoring situation. On the other hand, the stands also decouple the monitors from the tabletop, reducing unwanted vibrations. If there is no more room for the monitors on the table, it is best to use height-adjustable monitor stands: Thanks to their pull-out mechanism, the stands bring the monitors to "ear level" while at the same time providing firm support for the speakers.





STUDIO

Basics for the Home Studio

They exist in every area: The little things without which working would not be possible at all properly. The absolute basics of the equipment. Here we show you some of these little helpers for the area of studio technology.

HEADPHONES



OMNITRONIC
SHP-950M
High quality
monitor stereo
headphones

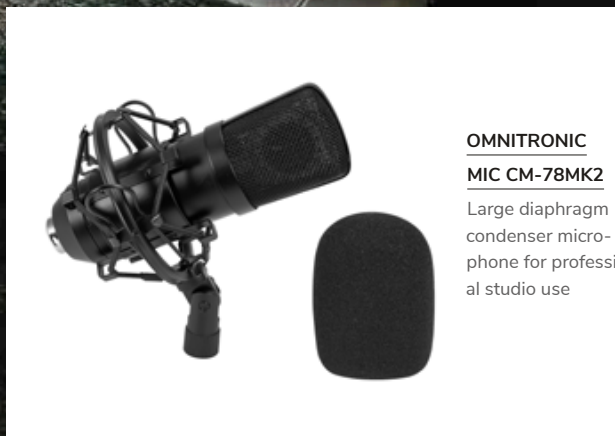
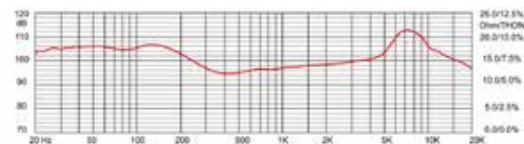

OMNITRONIC
MIC CM-78MK2
Large diaphragm
condenser micro-
phone for profession-
al studio use



OMNITRONIC
SHP-940M
High quality
monitor stereo
headphones



OMNITRONIC AS-01



OMNITRONIC AS-02



OMNITRONIC AS-03, foldable



OMNITRONIC AS-04, foldable incl. tripod

ABSORBERSYSTEMS

Not every room offers optimal conditions for voice, vocal or instrumental recording. To shield the microphone from unwanted reverberation, you can use an absorber system. These systems are available in various designs; for example, there is also a mobile version that can be mounted on a small table stand and easily folded for transport. For permanent stationary use in the studio, the versions that are firmly screwed onto a tripod and remain there are more suitable.

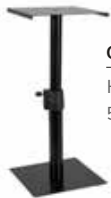

OMNITRONIC TMO-1

Height adjustable table stand 31-52 cm, loadable up to 25 kg

TABLESTAND

Depending on the spatial conditions in the home studio, the technology must be accommodated sensibly - this is where it sometimes makes sense to place the monitor boxes on the desk with the help of table stands. Thanks to the table stands, the monitors can be placed slightly higher and thus improve the monitoring situation for the producer.



OMNITRONIC TMO-2 black or white

Height adjustable table stand 25-42 cm, loadable up to 25 kg



OMNITRONIC MOTI-1

2 monitor stands, extendable from 20 to 30 cm, maximum load 20 kg each



OMNITRONIC MO-1

Monitor stand, extendable from 93 to 148 cm, maximum load 18 kg

MONITORSTANDS

If the monitors do not fit on the desk, as just mentioned, height-adjustable monitor stands provide an appropriate elevation for the speakers.

Thanks to their pull-out mechanism, the stands bring the monitors to "ear level" while providing firm support for the speakers.



OMNITRONIC EUMO-2

Height adjustable stand 73 to 111 cm, loadable up to 30 kg



OMNITRONIC MO-5

2 monitor stands, extendable from 75 to 130 cm, maximum load 30 kg each



OMNITRONIC MO-6

Stand extendable from 75 to 119 cm and loadable up to 18 kg

Good sound in every corner

Installation solutions for sound reinforcement

Whether it's relaxed background music of a restaurant, upbeat rhythms to warm up on the sports field or after-work jazz in the bar: The right sound system makes the scene perfect in many situations. Here we show you what you need in terms of technical equipment to install a sensible sound reinforcement solution using three examples.

1

Sports field

The sound reinforcement of sports fields, soccer fields or tennis courts places certain demands on the technology used: The loudspeakers used must be weatherproof, since they are used outdoors all year round. In addition, long distances often have to be bridged with cables. Voice announcements should be well understood by the listener, and at the same time it would be nice if music could also be played in the field. Outdoor-capable ELA loudspeakers are best suited for these requirements: OMNITRONIC's weatherproof speakers can be operated outdoors all year round. Thanks to the 100 V technology used, mono signals can also be transported over long distances without major losses. The associated ELA amplifiers raise the voltage of the signal to 100 V for this purpose. In order to be able to play both voice announcements and music, a mixer is also used, to which the microphone and the internet radio with CD player and Bluetooth function are connected.



OMNITRONIC ODX-212T 100V

Weather-proof 12" wall speaker with top-quality sound, 300 W RMS



OMNITRONIC PAP-650 ELA-Verstärker

PA power amplifier, 650 watts



OMNITRONIC EM-312

Microphone line mixer,
6 mono + 3 stereo channels



OMNITRONIC TUNA-NET-CD 19"

Internet radio with DAB+, FM, CD player, microSD slot, Bluetooth and UPnP/DLNA support



OMNITRONIC MIC SHD-1

Dynamic gooseneck microphone



If sound is to be provided to a larger restaurant with indoor and outdoor seating areas, suitable loudspeakers are needed for outdoor use on the one hand, and speakers for sound reinforcement of the interior on the other. Here, too, it makes sense to use ELA technology: Easily bridging long cable distances. With a suitable mixing amplifier, the volume of the different restaurant areas can be controlled independently of each other - for example, the volume can be increased on the terrace, while the music is quieter in the toilet area. À propos: In the toilet area, where wall speakers would unnecessarily further restrict the already sparse space, it is best to resort to in-ceiling speakers. In a large restaurant, an easy-to-operate device that all employees can set up without major training is a good choice as a feed.



OMNITRONIC ODP-206T 100V
2 weatherproof 6" wall speakers with mount, 20/40/80 W RMS

2

Restaurant with outdoor area



Zone 2

Zone 1

Zone 3



OMNITRONIC MAVZ-360.6P

6-zone PA mono mixing amp, MP3 player & IR remote, zones switchable, 360 W



OMNITRONIC EP-220NET

19" preamplifier with internet radio, DAB+, Bluetooth and IR remote control



OMNITRONIC OD-6T 100V
Weatherproof wall speaker pair (IP65) with 6.5" woofers and 32 W RMS



OMNITRONIC CSH-4

2-way flush-mount coaxial speaker, LF: 4" HF: 0.75" 100 V, 40 W RMS



In contrast to the restaurant described on the left, the cable paths are shorter in a smaller bar; that's why you don't necessarily have to rely on ELA technology here. Therefore, it is worth looking for installation loudspeakers that blend unobtrusively into the overall appearance of the bar, but deliver good results in terms of sound. Combined with a suitable amplifier, different zones can be sounded here as well: The bar, the guest room and the toilets can be played at different volumes. A player that can play music from various sources and is easy to operate is best used as the feed player.

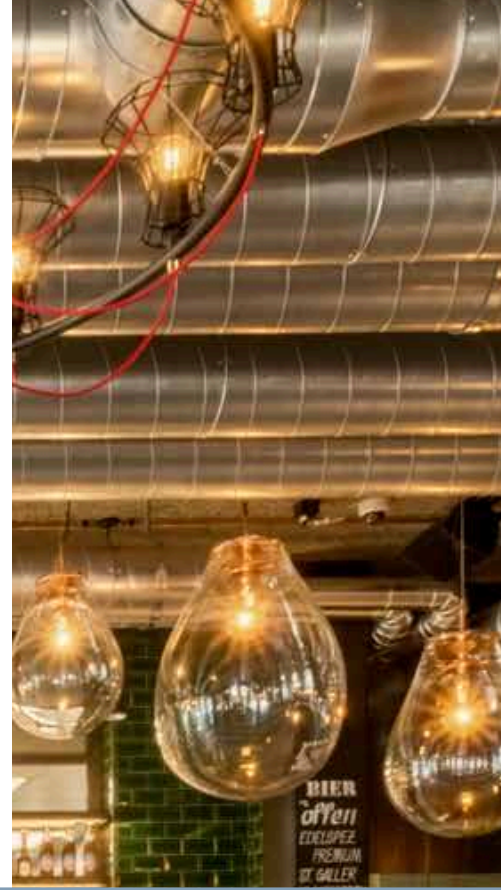

3 Bar with several rooms

OMNITRONIC EP-220PS

Universal 9.5" preamplifier with audio player, Bluetooth and FM radio



OMNITRONIC DJP-604

4-channel class D amplifier in 9.5" housing, 4 x 150 W / 4 ohms, 4 x 80 W / 8 ohms



OMNITRONIC C-50

Passive 2-way speaker pair with mount, 5" woofers and 40 W RMS

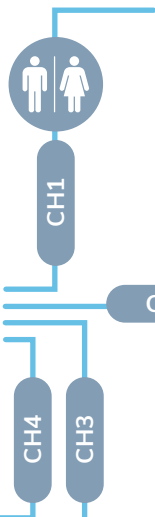

OMNITRONIC CSX-6

2-way coaxial speaker (Ø 202 mm), LF: 5,5" HF: 1", 100 V, 20 W RMS



OMNITRONIC ODP-204 16 ohms

2 weatherproof 4" wall speakers with mount, 40 W RMS



OMNITRONIC OD-8 80hm

2 weatherproof speakers with mount, 8" woofer, 1" tweeter, 50 W RMS



ARMIN-WOLF-BASEBALL-ARENA // REGENSBURG

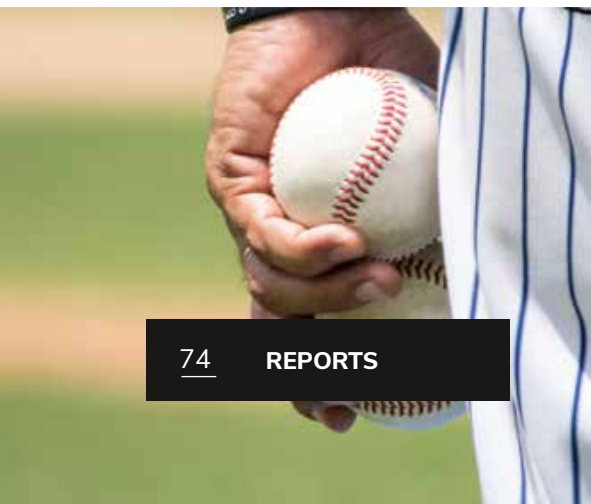

In Europe's largest baseball stadium in Regensburg, 16 ODP loudspeakers from OMNITRONIC now provide the appropriate sound reinforcement in the outdoor area. In the interior rooms, iFix-7 speakers from CELTO Acoustique were installed. An EP-220NET and three XPA-3004 from OMNITRONIC were used as feeds and amplifiers.

The company PRO EVENT GmbH from Barbing was responsible for the realization of the new sound reinforcement solution.



OMNITRONIC ODP-206
Installation Speaker 16 ohms black 2x

2 weatherproof 6" wall speakers with mount, 80 W RMS



CELTO ACOUSTIQUE iFIX7 2-Way
Coaxial Speaker black

Big sound in a small package, mounting bracket included



OMNITRONIC EP-220NET
19" preamplifier with internet radio, DAB+, Bluetooth and IR remote control



OMNITRONIC XPA-3004 Amplifier
4-channel PA amplifier with integrated limiter, 4 x 750 W / 4 ohms, 4 x 500 W / 8 ohms

ALL YOU NEED FOR BETTER TRACKS

Download one issue of BEAT magazine
including Pro Tools | First and the modular amp
Overloud TH-U^{BEAT} and start your next hit.

Free of charge:
www.bit.ly/FreeBeat187

For
Free!



NEW EVERY MONTH!

only 4.99 Euro per issue | www.plugins-samples.com



ZENTRAL essen & trinken // AMBERG

After extensive renovation, the “Zentral” café on the market square in the heart of Amberg’s old town now offers its visitors not only food and drinks but also first-class sound. A total of 2000 W amplifier power, 25 loudspeakers and an impressive 1.1 km of cable were installed. Music can be streamed simultaneously in 5 zones, with individually adjustable volume and sound. The control is done conveniently via tablet or smartphone. The concept is convincing both in terms of sound and appearance.

The project was realized by Gellfart Audio from Berg (Germany).

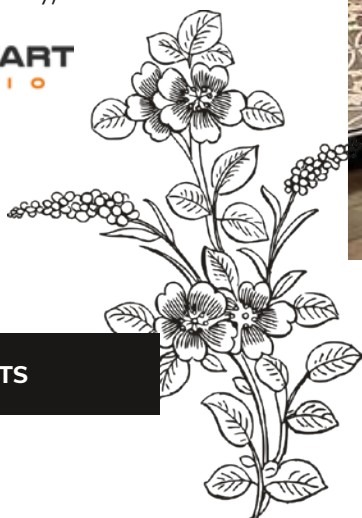



Big sound in a small format:



CELTO ACOUSTIQUE
iFIX6 2-Way Coaxial
Speaker



Christmas traditions

through the ages

When we think of Christmas, images arise automatically in our mind's eye. What do you see? Green fir trees, red baubles, and golden lights? Christmas trees and colorfully wrapped presents? Does Christmas smell like gingerbread and mulled wine in your imagination? Christmas, as we know it today, is characterized by these associations. But it was not always like this! Join us in taking a look at how the customs and traditions surrounding Christmas have changed over the centuries.





The first Christmas celebration

The first mention of a celebration on the occasion of Christ's birth can be found in the year 336:

At that time, December 25 was officially celebrated as an ecclesiastical holiday in Rome for the first time. On this date, many people originally celebrated the winter solstice and the sun god (Sol Invictus) - the "new" Christian holiday was thus helped by the fact that the inhabitants of Rome were already in a celebratory mood on this day.

Stars have a very special meaning during the Christmas season. When Jesus was born, a star shone unusually bright in the sky. To this day, people like to add Christmas touches with illuminated stars.

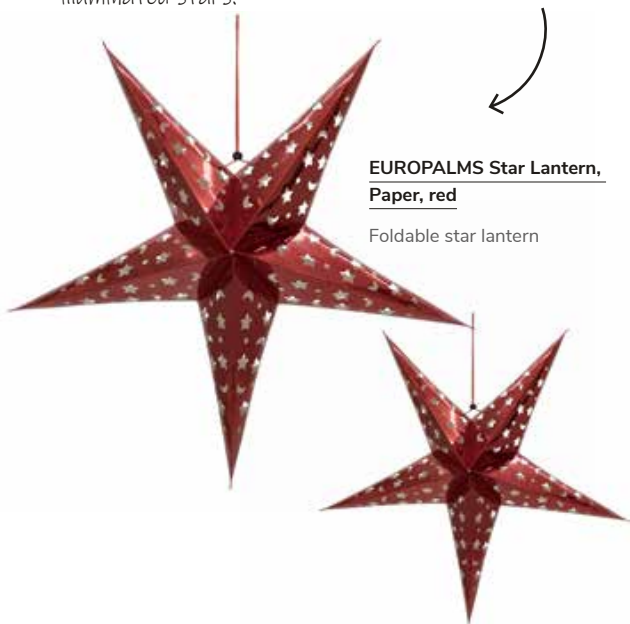

EUROPALMS Star Lantern,
Paper, red

Foldable star lantern

EUROPALMS Fir branch,
snowy, PE, 65cm

Essential for Christmas table decoration



The first Christmas tree

In the Middle Ages, a lot of superstition still prevailed in Europe; the belief that some ghosts and demons make life difficult for people was widespread. Therefore, in winter, people began to hang fir and yew branches in their living rooms to protect them from evil spirits. In addition to protection, the branches spread a fragrant fir scent for weeks - later this tradition developed into the Christmas tree that is so popular today.



EUROPALMS Christmas tree,
illuminated,
210cm

Since the 15th century, evergreen trees have been placed in living rooms around Christmas time; nowadays, reusable, artificial trees are also finding their way into more and more households.

Christmas traditions through the ages

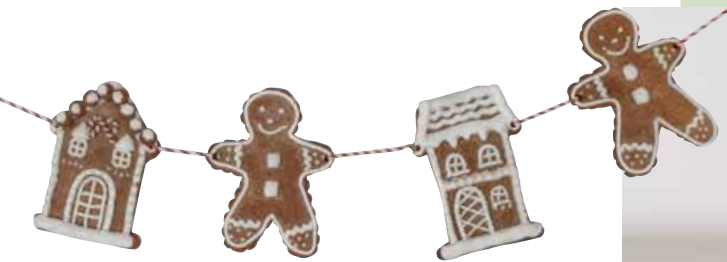

Tree decorations

Until 1917, the Advent season in the Catholic Church was also a time of fasting - during the 40 working days before Christmas, strict fasting rules were adhered to in preparation for the high feast. In anticipation of the breaking of the fast at Christmas, people hung treats such as candied apples, nuts, or gingerbread on the trees. Only at the end of Nativity Fast, at Christmas, or - depending on the region - New Year's Day or Epiphany, the decorations were allowed to be removed and eaten.



EUROPALMS
Deco Ball,
glitter

Over time, this custom changed and instead of food, more decorative things and small gifts found their place in the Christmas trees. The candied apples were replaced by glass balls, which soon became more and more colorful. Today you can find all kinds of decorations in different styles on Christmas trees: From straw stars to tinsel, from golden angels to flashing LED balls.



EUROPALMS LED Snowball
15cm, red

High-quality plastic sphere with four vertical circumferential LED rows



Gifts

It is often the greatest thing for children about Christmas: The gift-giving ceremony. The custom of giving each other small gifts first appeared in the late Middle Ages. At first, only well-heeled citizens and farmers gave their employees something for Christmas; poor people were also given a mild gift. Later, this custom was extended to children - since the 19th century, people of all ages have been giving each other presents.

Nowadays, electronic devices such as smartphones and laptops are particularly popular gifts, but musical instruments and traditional toys also enjoy enduring popularity.

Whether traditional or modern: We wish you a relaxing and wonderful Christmas season!



GIFT IDEAS

DIMAVERY AC-303 Classical Guitar, Maple

Classical guitar 4/4



EUROLITE LED BCW-4 Beam Effect



Compact mirror ball effect with a radiating dome and LED ring

OMNITRONIC TMO-2 Monitor Stand

Adjustable desktop stand
25-42 cm, max. load 25 kg



OMNITRONIC BMS-1C USB Con- denser Broadcast Microphone Set

With USB condenser microphone,
table mount, pop filter and spider



DIMAVERY UK-200 Tenor Ukulele, Koa

Tenor ukulele with cuta-
way and pickup-system



DIMAVERY Flute, german

BAR SHISHA COCKTAILS

LOUNGE to relax

The Arena Lounge in Viernheim is a bar/shisha lounge that wanted to offer its customers a cozy terrace in the outdoor area.



This wish became reality through Stefan Wörns (Eventstore Mannheim) with the help of artificial plants from EUROPALMS.

**ARENA
LOUNGE**
in
Viernheim

EUROPALMS
Lady Fern,
60cm



EUROPALMS Spider plant,
60cm



EUROLITE AKKU Table Light 2 RGB+WW

The table lamp creates a cozy atmosphere
- ideal for the summer terrace, balcony or
sunroom.

**EUROPALMS
Pothos bush,**
50cm



**EUROPALMS
Boston fern,**
green, 70cm





SAFETY FIRST

ATTENTION
 ALWAYS CHOOSE CASES THAT FIT EXACTLY, so that the HEAD-STOCK, NECK and BODY are not damaged during transport.

ABS cases by **DiMavery[®]** Instruments

SAFE TRAVELS!

Musicians on the road have a very special relationship with their instruments. To ensure that the best buddy doesn't get damaged between gigs, it needs a shock-proof and well-padded environment: a sturdy case with a hard outer shell and soft foam core is ideal for this. We present some guitar cases that are perfect tour companions:

UNIVERSALLY SUITABLE FOR ALMOST ALL BODY SHAPES

Rectangular cases have the advantage that they fit electric guitars and electric basses of various body shapes. The neck of the instrument is well padded on both sides in foam, and there is a rectangular recess in the padding for the body.

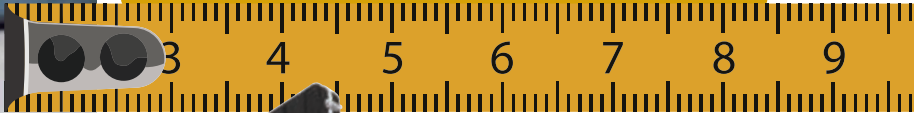

ABS CASE FOR E-GUITAR

Rectangular case for transporting electric guitars of various designs

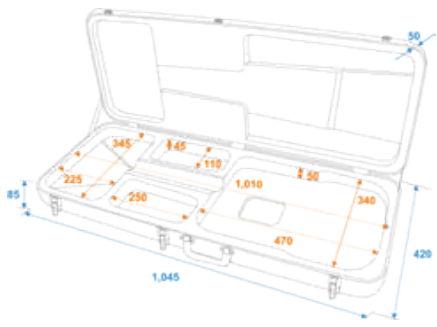

ABS CASE FOR E-BASS

Rectangular case for the transport of electric basses of various designs.

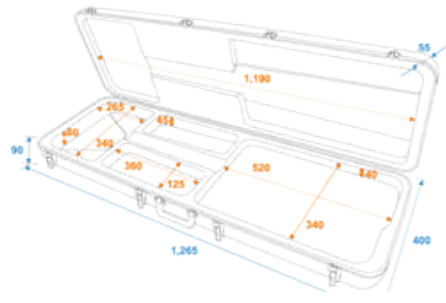

ABS =

ABS does not stand for “anti-blocking system” in these cases - the abbreviation reveals much more what the stable outer wall of the cases is made of: the hard plastic is correctly called Acrylonitrile Butadiene Styrene Copolymer.



ABS CASE FOR LP-GUITAR

Guitars in the classic, slightly bulbous LP/Single Cut shape feel right at home in this padded case.

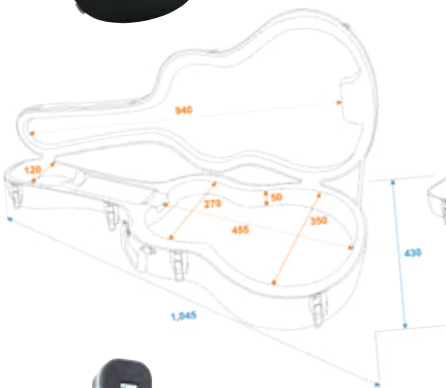

ABS CASE FOR E-GUITAR

The cases for slimmer electric guitars (like ST-, T-Style and Double Cut models) support the instrument at the neck, but leave enough space in the lower area for potentiometers and co.

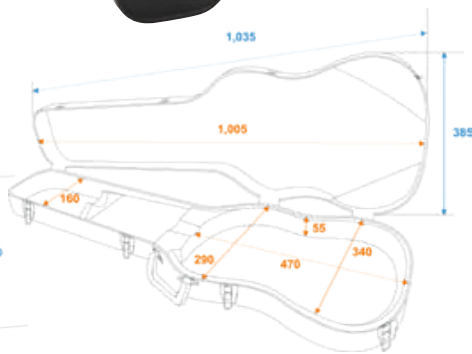

ABS CASE FOR E-BASS

The long neck of an electric bass fits perfectly in this customized case and is at the same time well protected from shocks by foam.

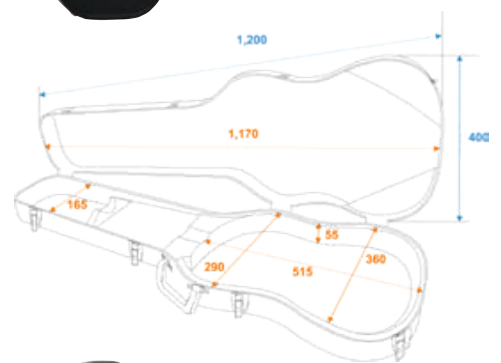

ABS CASE FOR WESTERN GUITAR

Whether on the way to the stage or to the campfire: thanks to the ABS case for acoustic guitars, the instrument is well protected.



ABS CASE FOR CLASSICAL GUITAR

The bulbous body of the classical guitar finds space in the lower part of the case, while the neck is supported by a thick foam block.



ABS CASE FOR JUMBO GUITAR

There is also a suitable ABS case with carrying handle for the large curves of the jumbo guitar.



QUIZ: LETTUCE & LETTERS



Just like in a good salad, a lot of things have been mixed up on this double page. The letters have to be put in the right order for the solution word at the end of the double page. As an aid to thinking, you will find randomly arranged illustrations of the terms.

Good luck!



_____ _____
RANNSEC

_____ _____
FLOORCEICH



_____ _____
ARSEL

SAFEGLICHT



_____ _____
TAGPLINATICH

WUROSOFEF

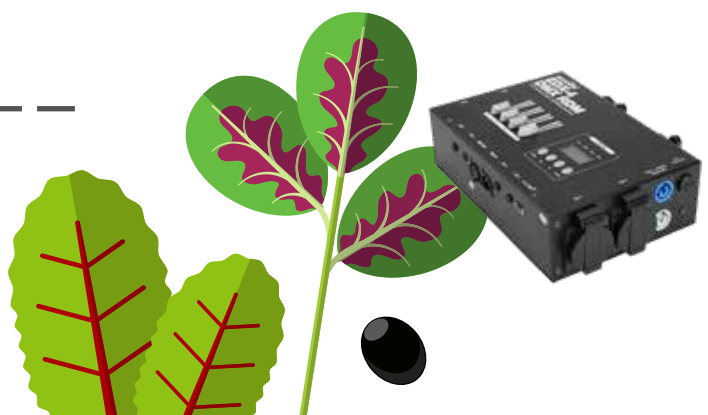



TAGENS DATS

10

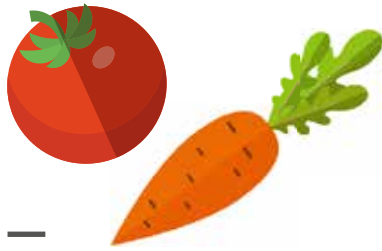

TOGO BIF

6

9

MIXARD

4

RAMBORLIRL



1

MIRDEM



RITARMEYROX

3

LOCIHAVOPERELMARIN



Solution:

1 2 3 4 5 6 7 8 9 10



Among all entries of the correct solution word until 31.01.2023 to redaktion@movemagazin.de we will raffle a EUROLITE freeDMX AP Wi-Fi Interface and a premium version of the new EUROLITE Light Captain App.



MINI WIRELESS MICROPHONE SYSTEM



The MIPASSPORT miniature radio system from RELACART is ideal for videographers and vloggers. The portable transmitter with integrated condenser microphone is simply attached to the speaker's clothes with a clip, the receiver to the camera. The connection from the receiver to the camera is then established using a 3.5 mm jack. The system is battery operated and runs for approximately 8 hours on one charge.



MIPASSPORT[®]

**2.4G TRANSMISSION
LICENSE-FREE**

STRIVE FOR PERFECTION

Switch the output gain of the microphone to meet the needs of the different occasion

SEARCH FOR TRUE SOUND

Intelligent noise reduction provides you with clear and moving sounds at any time

STRONG ENDURANCE

It can be used up to 8h after charging via USB-C



TRM-202MK3

2-channel rotary mixer with
3-band frequency isolator for DJs

Imprint

Publisher:

Steinigke Showtechnic GmbH
Andreas-Bauer-Straße 5
97297 Waldbüttelbrunn
Germany
info@steinigke.de

Owner:

Bernd Steinigke

Managing directors:

Matthias Schwab, Bernd Steinigke

Responsible for content and advertisements:

Anja Metz, marketing@steinigke.de

Print:

AKONTEXT s.r.o.

Editor in chief:

Anja Metz

Editors:

Anja Metz, Andreas Zöllner, Simon Alsheimer,
Petra Spanheimer

Art director:

Daniel Bergauer

Graphic:

Tatjana Franz, Nadine Page,
Marlon Kuchenmeister, Daniel Bergauer

Project manager print:

Christian Hold

Photos:

Own production, istockphoto.com,
shutterstock.com, unsplash.com, pexels.com,
pixabay.de

The content pages of this Move magazine were printed on environmentally friendly recycled paper.

Availability, technical changes and errors exempted. All images similar, some symbol photos.



XIRA

OMNITRONIC XIRA-215A Active 2-Way Speaker FIR-DSP

With 300 watts RMS power for the woofer and 50 watts RMS for the tweeter, XIRA makes your stomach quiver. The DSP-controlled blamp amplifier in Class D design offers four practical presets that ensure consistently good sound for any application: „MUSIC“ provides a slight bass and treble boost, „DJ“ gives the sound more presence and bass, „MONITOR“ is the right choice for use as a floor monitor and „SUB“ always fits when an additional subwoofer is used.

